

EC centrifugal fans RadiCal

Product Catalog 2023-02

ebmpapst

engineering a better life





ebmpapst

engineering a better life

Ready for the challenges of the future.

There are enormous legal, social and economic requirements for tomorrow's ventilation and air conditioning. If you want to master them with strength while conserving resources, you need strong companions. Just like the RadiCal with revised EC motors. Cleverly developed for sizes 190 to 250 or 190 to 225 in a scroll housing.



Higher air performance in the same installation space



High energy efficiency



Impressively durable EC technology



Optimum noise characteristics

The RadiCal 190-250

	Page		Page
Information	4	The RadiCal upgrade / ebm-papst FanScout	4
		GreenIntelligence / Engineering a better life	6
		Product overview RadiCal 190-250	8
		Characteristics overview RadiCal 190-250	10
RadiCal 190 - 250	12	EC centrifugal fans - RadiCal 190	18
		EC centrifugal modules - RadiCal 190	23
		EC centrifugal fans - RadiCal with housing 190	26
		EC centrifugal fans - RadiCal 220	30
		EC centrifugal modules - RadiCal 220	34
		EC centrifugal fans - RadiCal 225	38
		EC centrifugal modules - RadiCal 225	42
		EC centrifugal fans - RadiCal with housing 225	46
		EC centrifugal fans - RadiCal 250	50
		EC centrifugal modules - RadiCal 250	54
Accessories	58	FlowGrid air inlet grill	60
		Intake guard grill	61
		Inlet rings	62
Technology	64	Connection diagrams	66
		Airflow determination	67
		Technical parameters & scope	68
Contacts ebm-papst Worldwide	72	www.ebmpapst.com/contact	72

The RadiCal upgrade:

The latest-generation EC motor.

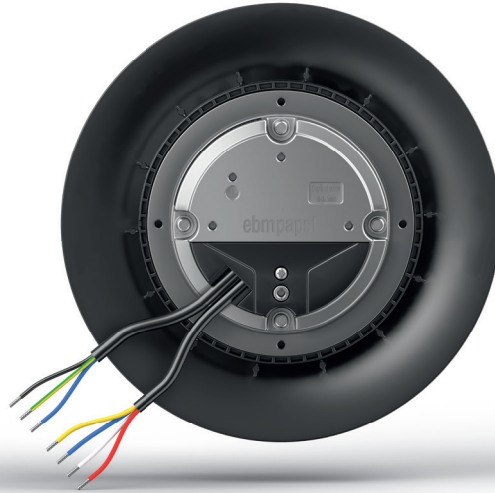

The new driving force.

Our aerodynamically optimized RadiCal impellers made of high-tech composite material combined with new revised EC motors. Compared to previous models, the EC motor impresses with its modified motor topology, which is more reliable and has improved moisture protection.

Depending on the application, it offers a range of performance classes and designs:

for example, the **ball bearings**. Our proven bearing is available as standard equipment:

- + Standard bearing, standard lubricant: suitable for general ambient air applications

Other options are available on request:

- + Sealed bearing, standard lubricant: protects against light levels of contamination and liquid contamination
- + Sealed bearing, low-temperature lubricant: suitable for applications in a low temperature range
- + Sealed stainless steel bearing: effective corrosion protection

Or the three **electronics** performance classes:

- + 85 W with control input 0-10V / PWM
- + 119 W with control input 0-10V / PWM
- + 170 W with control input 0-10V / PWM

Other options are available on request:

- + 170 W with RS485/MODBUS RTU interface

And the cable, designed as standard with a 450 mm length with splices.

Other options are available on request:

- + Cable lengths: 300, 600, 850, 1000, 1500 and 2000 mm
- + Plug for connection cable: "Universal Mate-N-Lok" or "Mini Universal Mate-N-Lok"

Features for wired communication

- + Locked-rotor protection
- + Soft start
- + Motor current limitation
- + Voltage output 10VDC
- + Thermal overload protection for electronics/motor, can be reset
- + Undervoltage and overvoltage detection
- + Control interface with SELV potential safely disconnected from the supply
- + Speed control
- + Control input 0-10V / PWM
- + Power limiter

Other options are available on request:

- + RS485/MODBUS-RTU (MODBUS V6)
- + Inputs/outputs (i/O) factory-configured by ebm-papst

RadiCal fans feature the following:

- + Very good system efficiency
- + Pleasant noise levels
- + Compact design
- + Fast availability
- + Simple commissioning
- + Finely tuned system with pre-configured motor / control electronics / impeller unit
- + Plug & play: fully pre-assembled unit ready to install
- + Single source: one contact partner for everything
- + Logistical advantages thanks to the complete unit
- + EC motors with magnets that use no rare earths

ebm-papst FanScout:

Click your way to the optimum RadiCal.

Our centrifugal fan can be configured individually for each application, and it is important to correctly consider all the relevant aspects when selecting it. When making your selection, you can rely on our experts' many years of experience – and on our professional fan selection software as well.

With its outstanding user-friendliness and real measured values, the ebm-papst FanScout has more than proven its worth already. It not only measures the performance of the individual fan components but also that of the fan as a complete system. The program allows you to quickly select the best fan for your application, to describe and modify the operating behavior and to document the technical specifications. Factors such as air performance, operating time and installation space can be taken into account in this process.

Exact presentation of the life cycle costs:

The costs of operation, acquisition, installation and service can be calculated for a defined period of time.

A practical advantage:

The software can be easily integrated into your device configuration program using the DLL interface.

The best part:

ebm-papst pre-selects the products that are suitable for you.

This saves you the trouble of searching through the broad product portfolio and helps you configure your application in advance.



Would you like to find out more?

All products from this catalog are summarized in the FanScout collection "RadiCal1_2023_02". We are happy to provide you with this collection on request. Or perhaps you have another question? Then get in touch with us for more information:

Ralf Mühleck, tel. +49 7938 81-7035, Ralf.Muehleck@de.ebmpapst.com
or visit us at www.ebmpapst.com/radipac

GreenIntelligence. *Making Engineers Happy.*



Why do our customers look so happy?

Because when it comes to digitalization and sustainability, we provide them with a clear competitive edge with GreenIntelligence. The intelligent control and networking of fans and drives makes applications more powerful and efficient. Together with a long product life and highly efficient EC technology, we achieve lasting reductions in energy costs and emissions.

Above all, residential ventilation units need to be reliable, economical and tailored to requirements. GreenIntelligence provides you with efficient fan solutions featuring smart networking capabilities and extensive analysis and control functions, and with digital services for simple, error-free planning.

This is how much GreenIntelligence there is in the new RadiCal with *MODBUS RTU interface* at 170 W:

- + Complete status monitoring
- + Notification when filter change required
- + Connection to smart home
- + Identifying additional environmental data
- + Optimal air quality everywhere



ebm-papst. Engineering a better life.

Who we are.

With over 20.000 different products, ebm-papst offers the right solution for just about any requirement. As the logical next stage in the development of our high-efficiency GreenTech EC technology, we believe that industrial digitalization offers the greatest future prospects for our customers. With GreenIntelligence, we already represent intelligently interconnected complete solutions that are second to none around the world.

Since it is our goal that all of our innovative hardware and software solutions become ever more powerful, compact, efficient and sustainable than their predecessors, we have grown over the years into the global technology leader for aerodynamics and drive technology.

What drives us.

However, our consistent pursuit of efficiency and progress has even deeper roots. After all, there is something that inspires us even more than our market position. It is the deep awareness that with our solutions, such as the RadiCal, we make many people's lives around the world more pleasant and safer, and therefore better. So the key driver of all our thoughts and actions?

That we are engineering a better life. It's the answer to the question of why it's worth getting up every day and doing our best.

Find out more at ebmpapst.com/betterlife

ebmpapst

engineering a better life

What you gain from this.

- 1. A technological advantage.**
With our EC technology and GreenIntelligence, we unite top energy efficiency with the benefits offered by the IoT and digital connectivity.
- 2. Sustainability as a way of life.**
We assume responsibility with our energy-saving products, environmentally friendly processes, and social commitment.
- 3. System expertise.**
As experts in advanced motor technology, electronics and aerodynamics, we provide ideal system solutions from a single source.
- 4. ebm-papst's spirit of invention.**
With more than 800 engineers and technicians, we will develop a solution that precisely fits your needs.
- 5. Personal proximity to you.**
Thanks to numerous sales offices worldwide.
- 6. Our quality standards.**
Our quality management is uncompromising – at every step of the process.

Olivia develops ventilation systems that react intelligently to environmental influences and reduce maintenance costs.

Green Intelligence helps us to turn
Engineering a better life into a reality.

What exactly does
this mean? Watch
the video now:



Product overview

EC centrifugal fans & modules

RadiCal 190 - 250

Information

Size	Nominal voltage range VAC	Max. input power W	Centrifugal fan 		Centrifugal module 		on Page
			Type	Part number	Type	Part number	
			190	1-200-240	85	VBS0190RSLBS	
1-200-240	120	VBS0190RSLDS		8300100019	VBH0190RSLDS	8300100022	
1-200-240	170	VBS0190RSLES		8300100184	VBH0190RSLES	8300100183	
220	1-200-240	85	VBS0220RSLDS	8300100032	VBH0220RSLDS	8300100033	30
	1-200-240	120	VBS0220RSLES	8300100072	VBH0220RSLES	8300100071	
	1-200-240	170	VBS0220RSLFS	8300100212	VBH0220RSLFS	8300100282	
225	1-200-240	85	VBS0225RSLDS	8300100296	VBH0225RSLDS	8300100295	38
	1-200-240	120	VBS0225RSLES	8300100169	VBH0225RSLES	8300100173	
	1-200-240	170	VBS0225RSLFS	8300100167	VBH0225RSLFS	8300100170	
250	1-200-240	85	VBS0250RSLES	8300100227	VBH0250RSLES	8300100228	50
	1-200-240	120	VBS0250RSLFS	8300100219	VBH0250RSLFS	8300100185	
	1-200-240	170	VBS0250RSLFS	8300100178	VBH0250RSLFS	8300100177	

Subject to technical changes. FanScout collection "RadiCal1_2023_02"

Product overview

EC centrifugal fans with housing

RadiCal 190 & 225

Size	Nominal voltage range VAC	Max. input power W	Centrifugal fan with housing		on Page
			Type	Part number	
190	1-200-240	120	VCS0190RSLDS	8300100337	26
	1-200-240	170	VCS0190RSLES	8300100440	
225	1-200-240	120	VCS0225RSLES	8300100470	46
	1-200-240	170	VCS0225RSLFS	8300100439	

Subject to technical changes. FanScout collection "RadiCal1_2023_02"

Characteristics overview

EC centrifugal fans RadiCal 190 - 250

Power brought to the operating point

The data shown is based on real performance measurements carried out on state-of-the-art chamber test rigs.

The entire fan unit, consisting of motor, control electronics, and impeller, is measured at varying load states.

This ensures that we obtain reliable data, and that you can count on these values being reached when selecting a fan.

So, there will be no nasty surprises when the fans are started up.

The measured data forms the basis for the FanScout design program, which is available on request.

This software can be used to calculate what operating costs are to be expected or to perform lifecycle cost analyses.

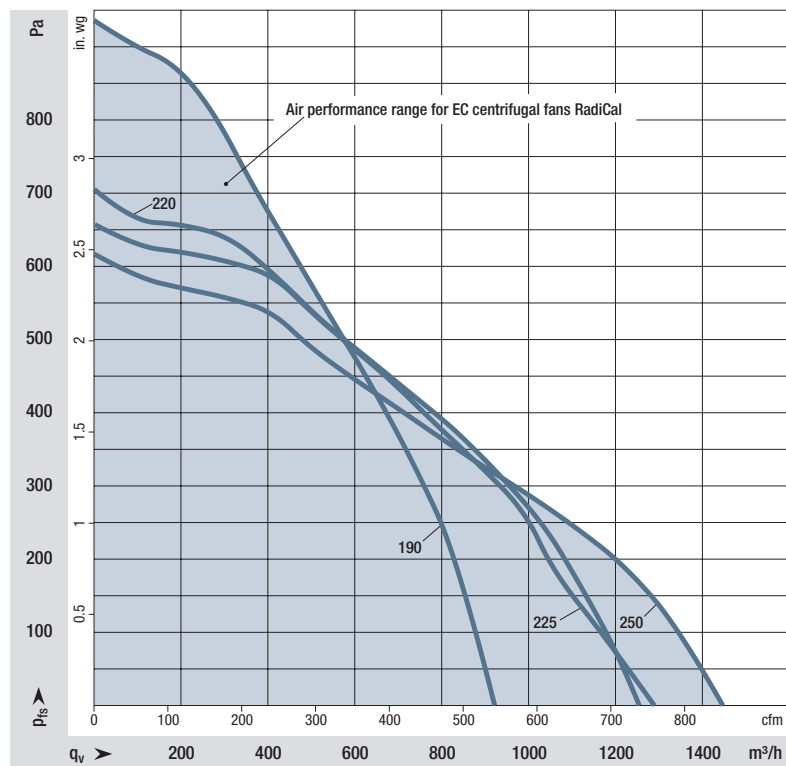

Max. air performance range of the RadiCal series. Max. air performance curves of sizes 190 - 250.

Characteristics overview

EC centrifugal modules RadiCal 190 - 250

EC centrifugal fans RadiCal with housing 190 & 225

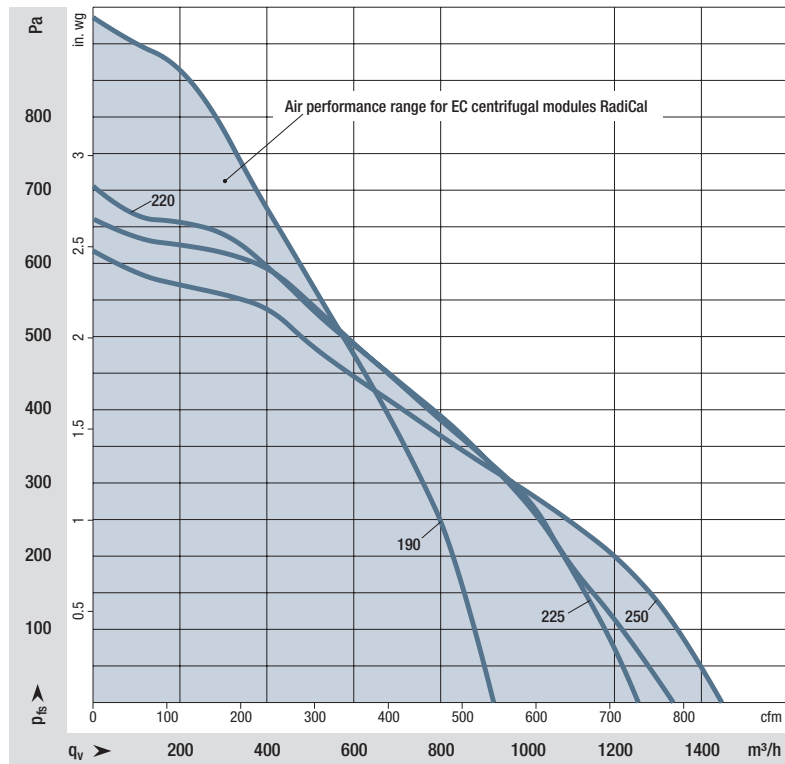

Max. air performance range of the RadiCal series. Max. air performance curves of sizes 190 - 250.

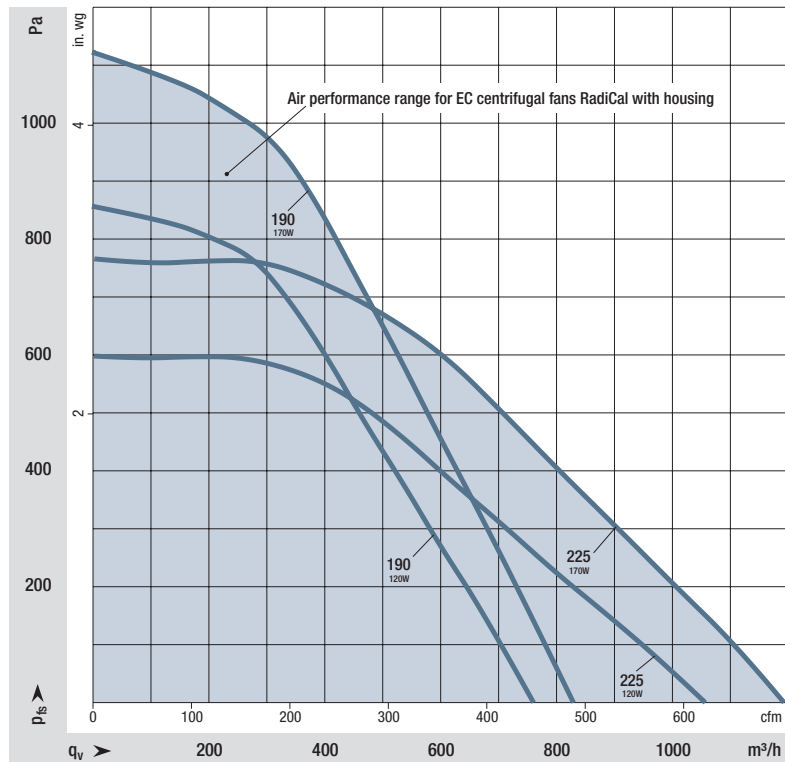

Max. air performance range of the RadiCal series. Max. air performance curves of sizes 190 & 225.

ebm-papst

EC centrifugal fans & modules



ebmpapst

engineering a better life

RadiCal 190 - 250

	Page
Tender specification	14
Fan size 190 - Centrifugal fan	18
Fan size 190 - Centrifugal module	22
Fan size 190 - Centrifugal fan with housing	26
Fan size 220 - Centrifugal fan	30
Fan size 220 - Centrifugal module	34
Fan size 225 - Centrifugal fan	38
Fan size 225 - Centrifugal module	42
Fan size 225 - Centrifugal fan with housing	46
Fan size 250 - Centrifugal fan	50
Fan size 250 - Centrifugal module	54

Tender specification

EC centrifugal fans & modules - RadiCal

Fan size 190 to 250

Direct-drive, single-inlet centrifugal fans with backward-curved one-piece impellers made of high-tech composite material, based on a GreenTech EC external rotor motor with integrated control electronics.

One-piece, jointless impeller, sizes 190 to 250 mm, made of high-tech composite material. Motor-impeller statically and dynamically balanced on two planes to balancing grade G 6.3 in accordance with DIN ISO 21940. GreenTech EC external rotor motors achieve or exceed the efficiency specifications as per efficiency class IE5 (IEC TS 60034-30-2:2016), magnets without the use of rare earths, maintenance-free ball bearings with long-term lubrication, theoretical nominal service life of at least 40.000 operating hours.

Soft start, integrated current limitation, extended voltage input 1~200-240 V, 50/60. The fan can be used with all standard power supply networks with unaltered air performance. Integrated control electronics, low-noise commutation logic; speed control; power classes 85/119/170 W, 170 W optionally with RS485/MODBUS-RTU interface, no shielded cables are required for the power supply. Cable brought out with splices or optionally with plug.

Fan module for wall mounting:

Sizes 190 to 250 manufactured as a compact, ready-to-install, flow-optimized support unit for wall mounting made of high-performance plastic. Any installation position, rotor on top on request. Any work required for isolation from structure-borne noise is to be performed by the customer. The fan satisfies the applicable EMC guidelines and requirements with regard to harmonic effects (see applicable data sheet for specific figures). Documentation and marking in accordance with the applicable EU directives. Reliable performance data, air performance measurements taken on an intake-side chamber test rig in accordance with ISO 5801 and DIN 24163. Noise measurements taken in an anechoic room in accordance with DIN EN ISO 3745.

Integrated protective devices:

- + Configurable inputs/outputs (I/O) as standard
- + Locked-rotor protection
- + Soft start
- + Motor current limitation
- + Voltage output 10 VDC
- + Thermal overload protection for electronics/motor, can be reset
- + Undervoltage and overvoltage detection
- + Control interface with SELV potential safely disconnected from supply
- + Speed control
- + Control input 0-10V / PWM
- + Power limiter

Optional:

- + Other requirements and specific requirements on request
- + MODBUS RTU (MODBUS V6), RS 485 for the 170 W version

FlowGrid air inlet grill:

FlowGrid air inlet grill tailor-made for the fan, to reduce assembly and system-related noise. FlowGrid made of high-grade composite material in one piece, available ready for installation and also suitable for retrofitting. Particularly suitable for confined intake conditions at the fan and/or if upstream turbulence-inducing fittings are unavoidable. The FlowGrid breaks up the turbulence fields and straightens the flow, resulting in distinct noise reduction.

Tender specification

EC centrifugal fans & modules - RadiCal

Fan size 190 to 250

Technical data:

Fan type	= _____
Part number	= _____
Air flow	qV = _____ m ³ /h, cfm
Stat. pressure increase	pfs = _____ Pa, in wg
Stat. overall efficiency	η_{esd} = _____ %
Operating speed	n = _____ min ⁻¹
Motor type	= EC motor
Type of control	= Speed control
Motor efficiency class	= IE5
Total power input	Ped = _____ kW
Specific fan power	SFP = _____ kW/(m ³ /s)
Nominal voltage range	U _N = _____ V
Line frequency	f = 50 / 60 Hz
Nominal current	I _N = _____ A
Degree of protection	= IP54
Sound power level	L _{WA} (A, in) = _____ / L _{WA} (A, out) = _____ dB(A)
Sound pressure level (at 1 m)	L _{PA} (A, in) = _____ / L _{PA} (A, out) = _____ dB(A)
Perm. ambient temperature	T = _____ to _____ °C
Weight of fan	m = _____ kg

Refer to data sheet for dimensions and wiring.

Subject to change / Version 2022/10/12.



Tender specification

EC centrifugal fans - RadiCal with housing

Fan size 190 & 225

Direct-drive, single inlet centrifugal fans with backward-curved one-piece impellers made of high-tech composite material, based on a GreenTech EC external rotor motor with integrated control electronics, installed in a scroll housing.

One-piece, jointless impeller, sizes 190 to 225 mm, with seven blades made of high-tech composite material. Motor-impeller statically and dynamically balanced on two planes to balancing grade G 6.3 in accordance with DIN ISO 21940. GreenTech EC external rotor motors achieve or exceed the efficiency specifications as per efficiency class IE5 (IEC TS 60034-30-2:2016), magnets without the use of rare earths, maintenance-free ball bearings with long-term lubrication, theoretical nominal service life of at least 40.000 operating hours.

Soft start, integrated current limitation, extended voltage input 1~200-240 V, 50/60. The fan can be used with all standard power supply networks with unaltered air performance. Integrated control electronics, low-noise commutation logic; speed control; power classes 119/170 W, 170 W optionally with RS485/MODBUS-RTU interface, no shielded cables are required for the power supply. Cable brought out with splices or optionally with plug.

Version in housing design:

Sizes 190 to 225, designed as ready-to-install housing construction. Construction is made of high-tech composite material, fastening options for installation available. Flexible installation position (please note protection class). Any work required for isolation from structure-borne noise is to be performed by the customer. The fan satisfies the applicable EMC guidelines and requirements with regard to harmonic effects (see applicable data sheet for specific figures). Documentation and marking in accordance with the applicable EU directives. Reliable performance data, air performance measurements taken on an intake-side chamber test rig in accordance with ISO 5801 and DIN 24163. Noise measurements taken in an anechoic room in accordance with DIN EN ISO 3745.

Integrated protective devices:

- + Configurable inputs/outputs (I/O) as standard
- + Locked-rotor protection
- + Soft start
- + Motor current limitation
- + Voltage output 10 VDC
- + Thermal overload protection for electronics/motor, can be reset
- + Undervoltage and overvoltage detection
- + Control interface with SELV potential safely disconnected from supply
- + Speed control
- + Control input 0-10V / PWM
- + Power limiter

Optional:

- + Other requirements and specific requirements on request
- + MODBUS RTU (MODBUS V6), RS 485 for the 170 W version
- + Constant volume control

FlowGrid air inlet grill:

FlowGrid air inlet grill tailor-made for the fan, to reduce assembly and system-related noise. FlowGrid made of high-grade composite material in one piece, available ready for installation and also suitable for retrofitting. Particularly suitable for confined intake conditions at the fan and/or if upstream turbulence-inducing fittings are unavoidable. The FlowGrid breaks up the turbulence fields and straightens the flow, resulting in distinct noise reduction.

Tender specification

EC centrifugal fans - RadiCal with housing

Fan size 190 & 225

Technical data:

Fan type		= _____
Part number		= _____
Air flow	qV	= _____ m ³ /h, cfm
Stat. pressure increase	pfs	= _____ Pa, in wg
Stat. overall efficiency	η_{esd}	= _____ %
Operating speed	n	= _____ min ⁻¹
Motor type		= EC motor
Type of control		= Speed control
Motor efficiency class		= IE5
Total power input	Ped	= _____ kW
Specific fan power	SFP	= _____ kW/(m ³ /s)
Nominal voltage range	U _N	= _____ V
Line frequency	f	= 50 / 60 Hz
Nominal current	I _N	= _____ A
Degree of protection		= IP54
Sound power level	L _{WA} (A, in)	= _____ / L _{WA} (A, out) = _____ dB(A)
Sound pressure level (at 1 m)	L _{pA} (A, in)	= _____ / L _{pA} (A, out) = _____ dB(A)
Perm. ambient temperature	T	= _____ to _____ °C
Weight of fan	m	= _____ kg

Refer to data sheet for dimensions and wiring.

Subject to change / Version 2022/10/12.

EC centrifugal fan with housing



FlowGrid air inlet grill

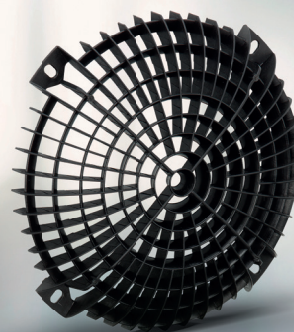

RadiCal 190

EC centrifugal fans, backward curved



Material/Surface

- Impeller: PP plastic
- Rotor: Thick-film passivated
- Electronics housing: Die-cast aluminum

Mechanical characteristics

- Number of blades: 7
- Drehrichtung (epM): Clockwise, viewed toward rotor
- Installation position: Any
- Condensation drainage holes: None, open rotor
- Mode: S1
- Motor bearing: Ball bearing

Additional Information

- Information about touch current, electrical connection, degree of protection, insulation class, environmental protection class, EMC standards as well as standards and approvals can be found in the product-specific data sheets.

from page 20	Drawings
from page 58	Accessories
from page 66	Connection diagrams and technical equipment
from page 68	Environment and general conditions
More at	www.ebmpapst.com/worldwide www.ebmpapst.com/

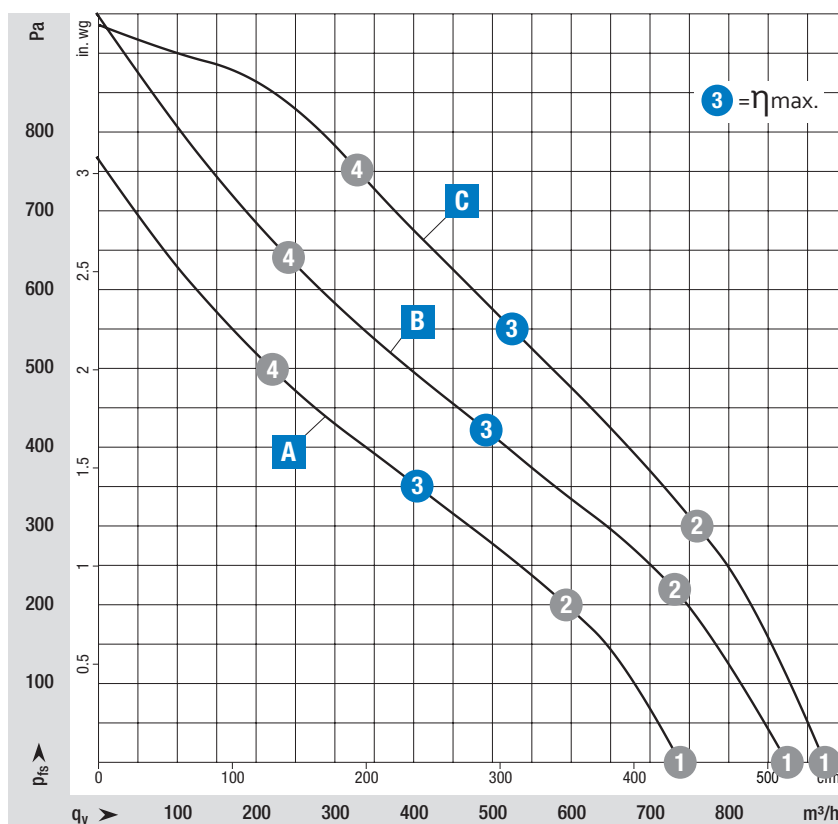



Measuring conditions

Air performance measured after: ISO 5801, installation category A, with ebm-papst inlet nozzle without contact protection.

Suction-side noise level: LwA according to ISO 13347, LpA measured at a distance of 1 m on the fan axis.

The specifications apply only under the specified measuring conditions and may change due to installation conditions.

In case of deviations from the standard design, the characteristic values must be checked in the installed condition!

Nominal voltage range 1- 200-240 VAC, 50/60 Hz			Characteristic Curve	Operating point	Nominal voltage	Speed n	Max. Input power P _{ed}	Max. Input current I	Sound power level L _{WA}	Max. back pressure	Perm. ambient temp.	Protection class	Connection diagrams and technical equipment	
Type	Part number	Fan type			V	rpm	W	A	dB(A)	Pa	°C			
VBS0190RSLBS	8300100027	Centrifugal fan		A	1	230	3,555	85	0.70	76	---	-25...+60	IP54	Page 66
					2	230	3,410	85	0.70	71				
					3	230	3,250	85	0.70	69				
					4	230	3,465	85	0.70	74				
VBS0190RSLDS	8300100019	Centrifugal fan		B	1	230	4,045	120	1.00	78	---	-25...+60	IP54	Page 66
					2	230	3,885	120	1.00	74				
					3	230	3,650	120	1.00	71				
					4	230	3,915	120	1.00	77				
VBS0190RSLES	8300100184	Centrifugal fan		C	1	230	4,500	170	1.35	82	---	-25...+60	IP54	Page 66
					2	230	4,360	170	1.35	77				
					3	230	4,150	170	1.35	75				
					4	230	4,330	170	1.35	77				

Subject to changes.

Values set in blue are nominal data at the operating point at maximum load.

RadiCal 190

A VBS0190RSLBS 8300100027 EC centrifugal fan - RadiCal

Dimensions in mm

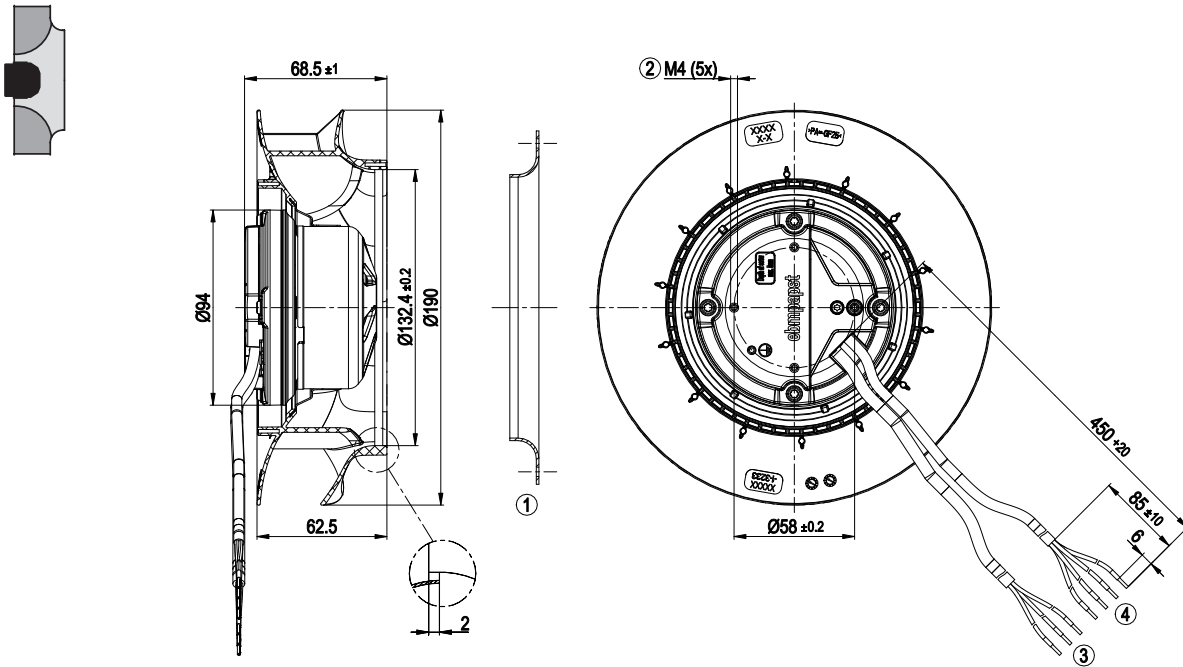

- ① Accessory part: inlet ring 09576-2-4013 not included in scope of delivery
- ② Max. clearance for screw 5 mm
- ③ Supply line (PWR) PVC AWG20, 3x splice
- ④ Control wire (CTRL) PVC AWG22, 4x splice

Pin assignment: See connection diagram
Mounting position: Any

B VBS0190RSLDS 8300100019 EC centrifugal fan - RadiCal

Dimensions in mm

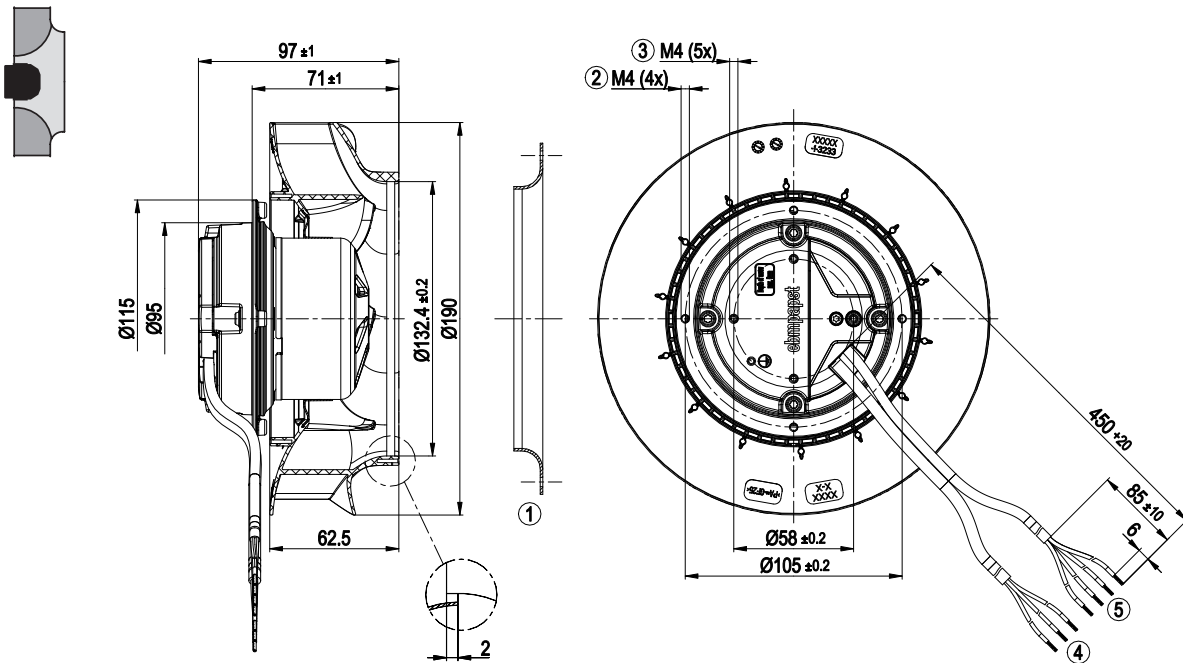

- ① Accessory part: inlet ring 09576-2-4013 not included in scope of delivery
- ② Max. clearance for screw 6 mm
- ③ Max. clearance for screw 5 mm
- ④ Supply line (PWR) PVC AWG20, 3x splice
- ⑤ Control wire (CTRL) PVC AWG22, 4x splice

Pin assignment: See connection diagram
Mounting position: Any

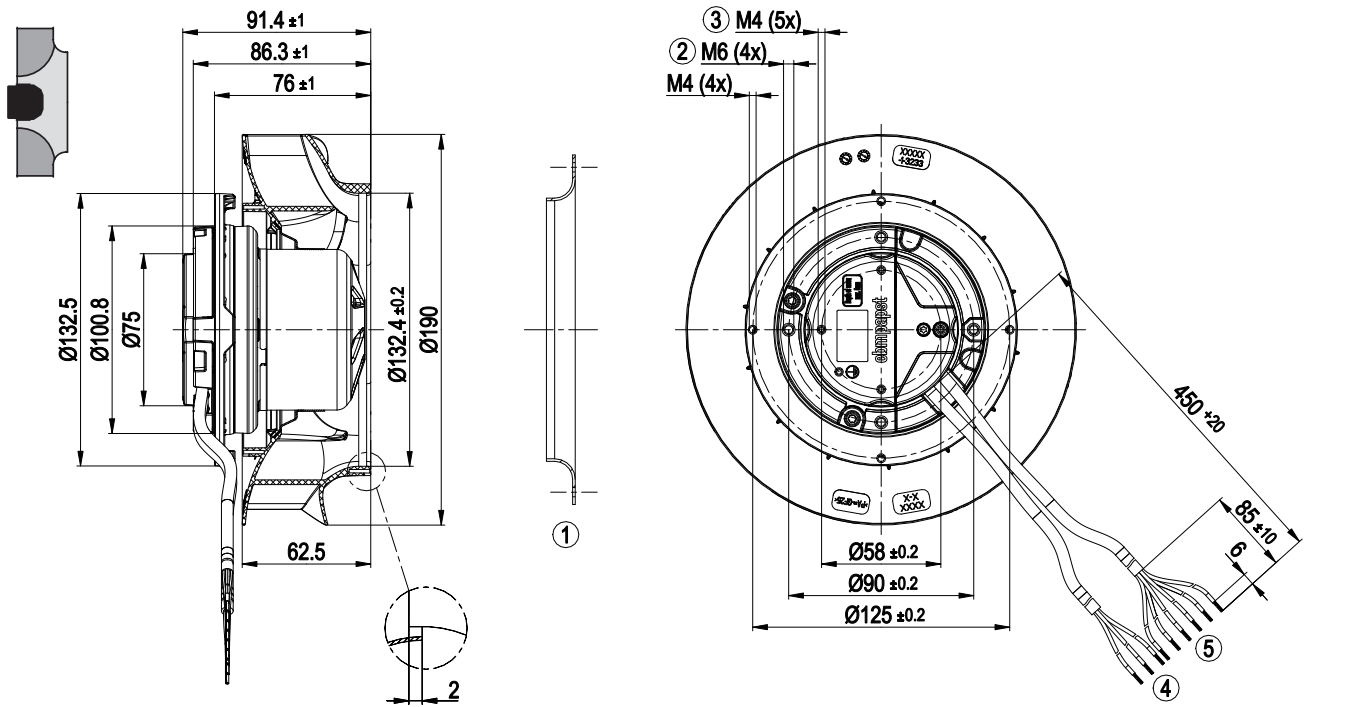

- ① Accessory part: Inlet ring 09576-2-4013 (not included in scope of delivery)
- ② Max. clearance for screw 10 mm
- ③ Max. clearance for screw 5 mm
- ④ Supply line (PWR) PVC AWG20, 3x splice
- ⑤ Control wire (CTRL) PVC AWG22, 4x splice

Pin assignment: See connection diagram
Mounting position: Any

RadiCal 190

EC centrifugal modules, backward curved

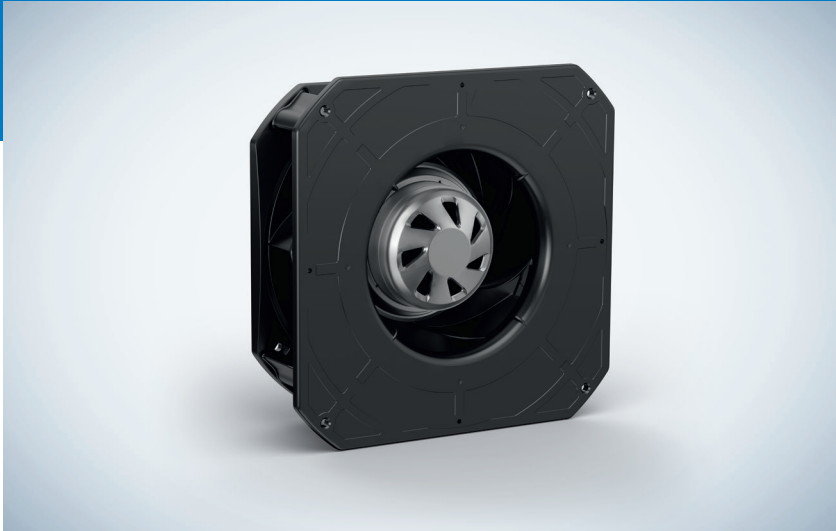

Material/Surface

- Impeller: PP plastic
- Rotor: Thick-film passivated
- Electronics housing: Die-cast aluminum

Mechanical characteristics

- Number of blades: 7
- Drehrichtung (epM): Clockwise, viewed toward rotor
- Installation position: Any
- Condensation drainage holes: None, open rotor
- Mode: S1
- Motor bearing: Ball bearing

Additional Information

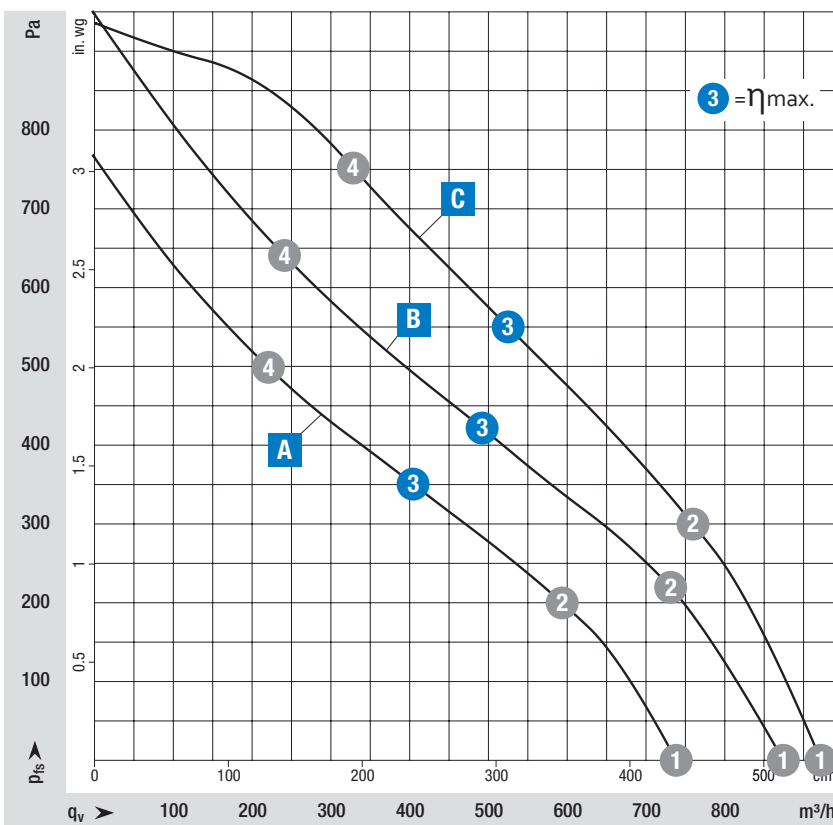

- Information about touch current, electrical connection, degree of protection, insulation class, environmental protection class, EMC standards as well as standards and approvals can be found in the product-specific data sheets.

from page 24	Drawings
from page 58	Accessories
from page 66	Connection diagrams and technical equipment
from page 68	Environment and general conditions
More at	www.ebmpapst.com/worldwide www.ebmpapst.com/



Measuring conditions

Air performance measured after: ISO 5801, installation category A, with ebm-papst inlet nozzle without contact protection.
Suction-side noise level: LWA according to ISO 13347, LpA measured at a distance of 1 m on the fan axis.
The specifications apply only under the specified measuring conditions and may change due to installation conditions.
In case of deviations from the standard design, the characteristic values must be checked in the installed condition!

Nominal voltage range 1- 200-240 VAC, 50/60 Hz			Characteristic Curve	Operating point	Nominal voltage	Speed n	Max. Input power P _{ed}	Max. Input current I	Sound power level LWA	Max. back pressure	Perm. ambient temp.	Protection class	Connection diagrams and technical equipment	
Type	Part number	Fan type			V	rpm	W	A	dB(A)	Pa	°C			
VBH0190RSLBS	8300100028	Centrifugal module		A	①	230	3,555	85	0.70	76	---	-25...+60	IP54	Page 66
					②	230	3,410	85	0.70	71				
					③	230	3,250	85	0.70	69				
					④	230	3,465	85	0.70	74				
VBH0190RSLDS	8300100022	Centrifugal module		B	①	230	4,045	120	1.00	78	---	-25...+60	IP54	Page 66
					②	230	3,885	120	1.00	74				
					③	230	3,650	120	1.00	71				
					④	230	3,915	120	1.00	77				
VBH0190RSLES	8300100183	Centrifugal module		C	①	230	4,500	170	1.35	82	---	-25...+60	IP54	Page 66
					②	230	4,360	170	1.35	77				
					③	230	4,150	170	1.35	75				
					④	230	4,330	170	1.35	77				

Subject to changes.

Values set in blue are nominal data at the operating point at maximum load.

RadiCal 190

A VBH0190RSLBS 8300100028 EC centrifugal module - RadiCal

Dimensions in mm

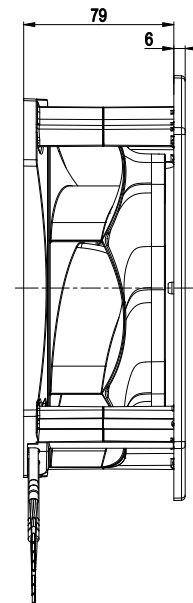
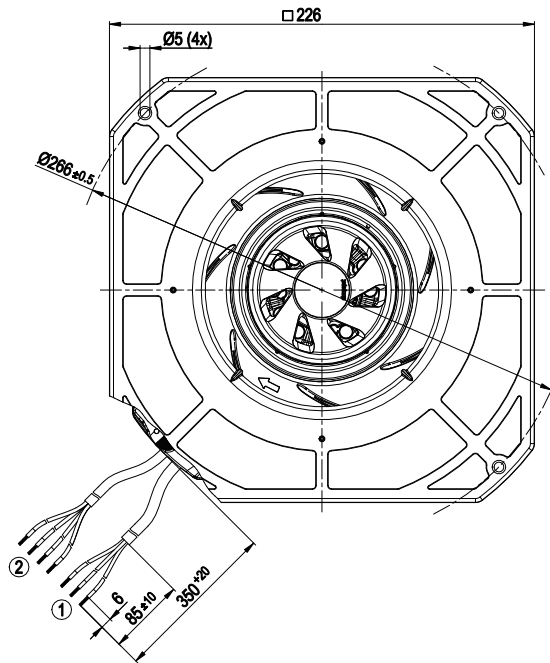

- ① Supply line (PWR) PVC AWG20, 3x splice
- ② Control wire (CTRL) PVC AWG22, 4x splice

Pin assignment: See connection diagram
Mounting position: Any

B VBH0190RSLDS 8300100022 EC centrifugal module - RadiCal

Dimensions in mm

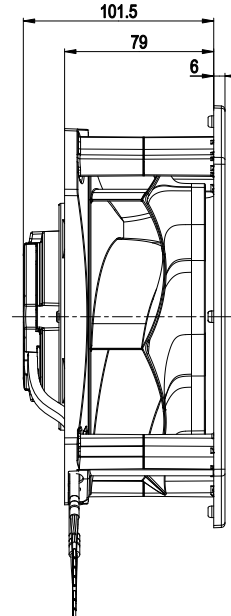
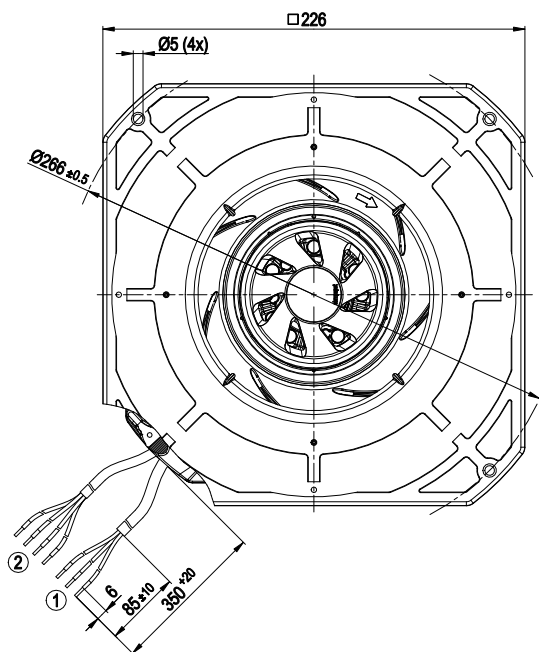

- ① Supply line (PWR) PVC AWG20, 3x splice
- ② Control wire (CTRL) PVC AWG22, 4x splice

Pin assignment: See connection diagram
Mounting position: Any

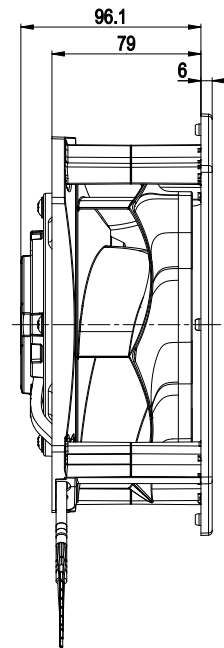
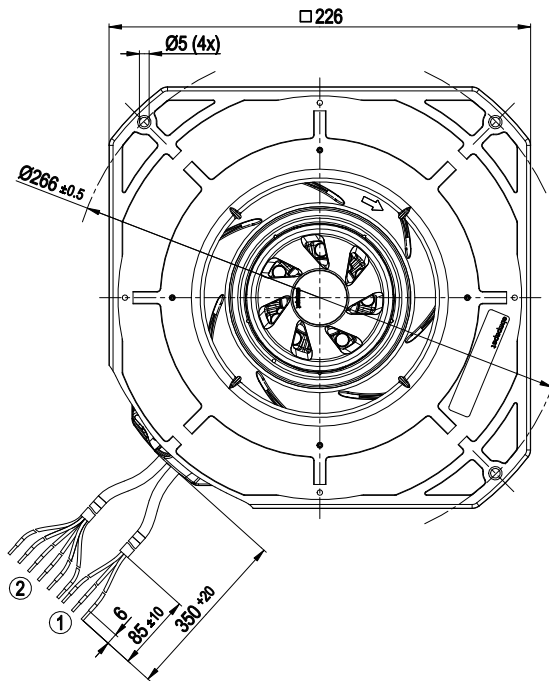

- ① Supply line (PWR) PVC AWG20, 3x splice
- ② Control wire (CTRL) PVC AWG22, 4x splice

Pin assignment: See connection diagram
 Mounting position: Any

RadiCal 190

EC centrifugal fans, backward curved with housing



Material/Surface

- Impeller: PP plastic
- Rotor: Thick-film passivated

Mechanical characteristics

- Number of blades: 7
- Drehrichtung (epM): Clockwise, viewed toward rotor
- Installation position: Any
- Condensation drainage holes: None, open rotor
- Mode: S1
- Motor bearing: Ball bearing

Additional Information

- Information about touch current, electrical connection, degree of protection, insulation class, environmental protection class, EMC standards as well as standards and approvals can be found in the product-specific data sheets.

from page 28	Drawings
from page 58	Accessories
from page 66	Connection diagrams and technical equipment
from page 68	Environment and general conditions
More at	www.ebmpapst.com/worldwide www.ebmpapst.com/

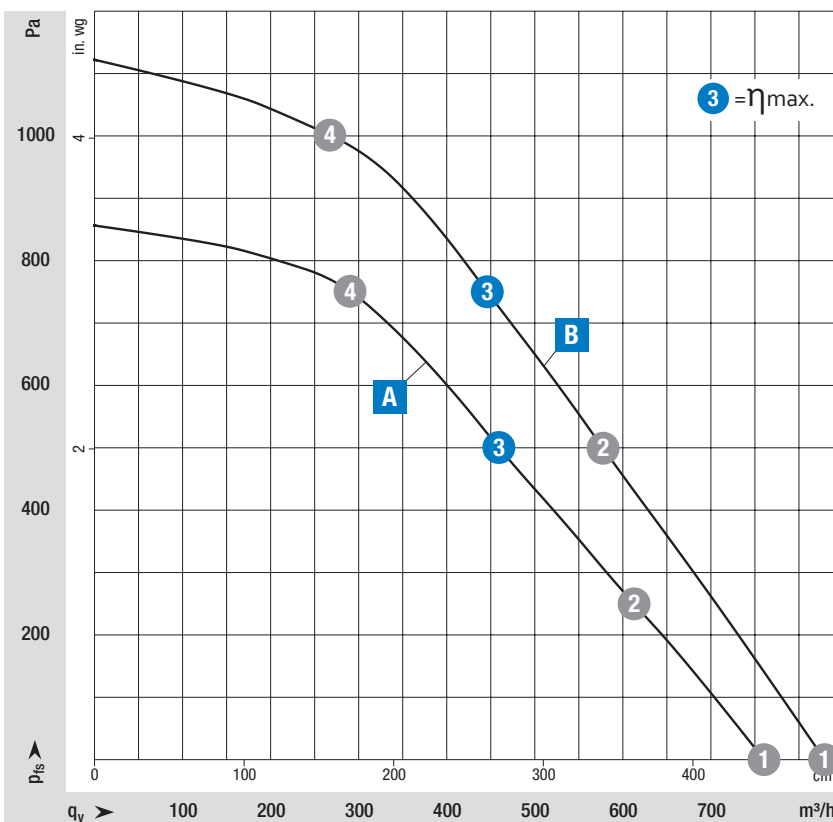



Measuring conditions

Air performance measured after: ISO 5801, installation category A, with ebm-papst inlet nozzle without contact protection.

Suction-side noise level: LWA according to ISO 13347, LpA measured at a distance of 1 m on the fan axis.

The specifications apply only under the specified measuring conditions and may change due to installation conditions.

In case of deviations from the standard design, the characteristic values must be checked in the installed condition!

Nominal voltage range 1- 200-240 VAC, 50/60 Hz			Characteristic Curve	Operating point	Nominal voltage	Speed n	Max. Input power P _{ed}	Max. Input current I	Sound power level LWA	Max. back pressure	Perm. ambient temp.	Protection class	Connection diagrams and technical equipment	
Type	Part number	Fan type			V	rpm	W	A	dB(A)	Pa	°C			
VCS0190RSLDS	8300100337	Centrifugal fan with housing		A	1	230	3,850	120	1.00	76	---	-25...+60	IP54	Page 66
					2	230	3,710	120	1.00	72				
					3	230	3,650	120	1.00	70				
					4	230	3,850	114	0.95	73				
VCS0190RSLES	8300100440	Centrifugal fan with housing		B	1	230	4,410	168	1.34	82	---	-25...+60	IP54	Page 66
					2	230	4,200	170	1.35	76				
					3	230	4,270	170	1.35	75				
					4	230	4,410	156	1.26	78				

Subject to changes.

Values set in blue are nominal data at the operating point at maximum load.

RadiCal 190

A VCS0190RSLDS 8300100337 EC centrifugal fan - RadiCal with housing

Dimensions in mm

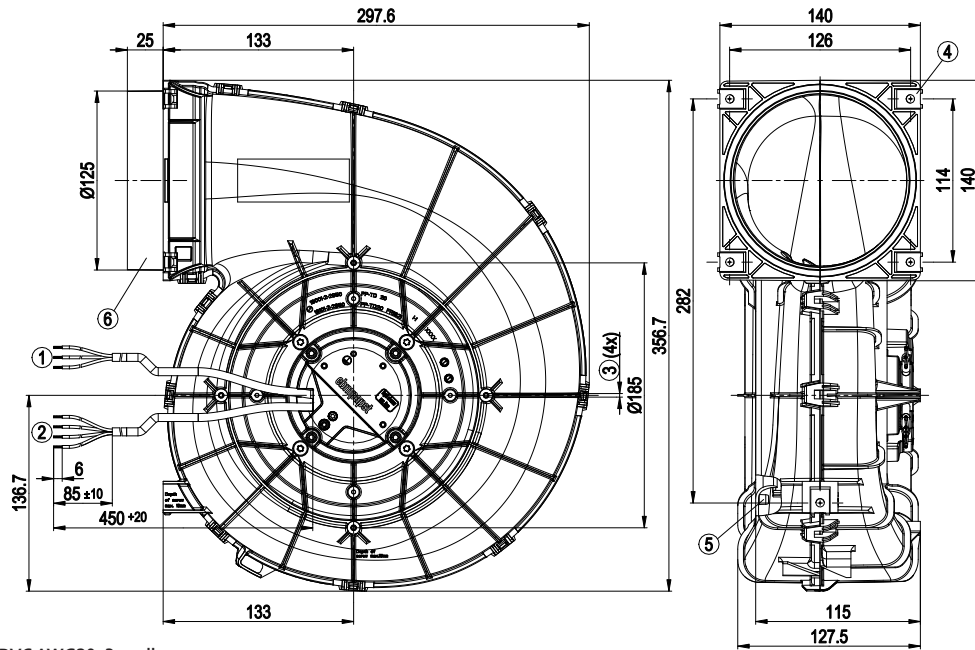

- ① Supply line (PWR) PVC AWG20, 3x splice
- ② Control wire (CTRL) PVC AWG22, 4x splice
- ③ Tapping hole prepared for self-tapping screw for fastening plastics (Remform) dia. 4 mm, clearance for screw max. 15 mm. The torque is to be determined on the basis of the screw.
- ④ 5x sheet metal nut for thread EN ISO 1478-ST4.8 (max. screw length 16 mm plus thickness of mounting material)
- ⑤ Screw-on domes are only permissible for Flowgrid!
- ⑥ Connecting sleeve not suitable for installation with pipe clamps

Pin assignment: See connection diagram
Mounting position: Any

B VCS0190RSLES 8300100440 EC centrifugal fan - RadiCal with housing

Dimensions in mm

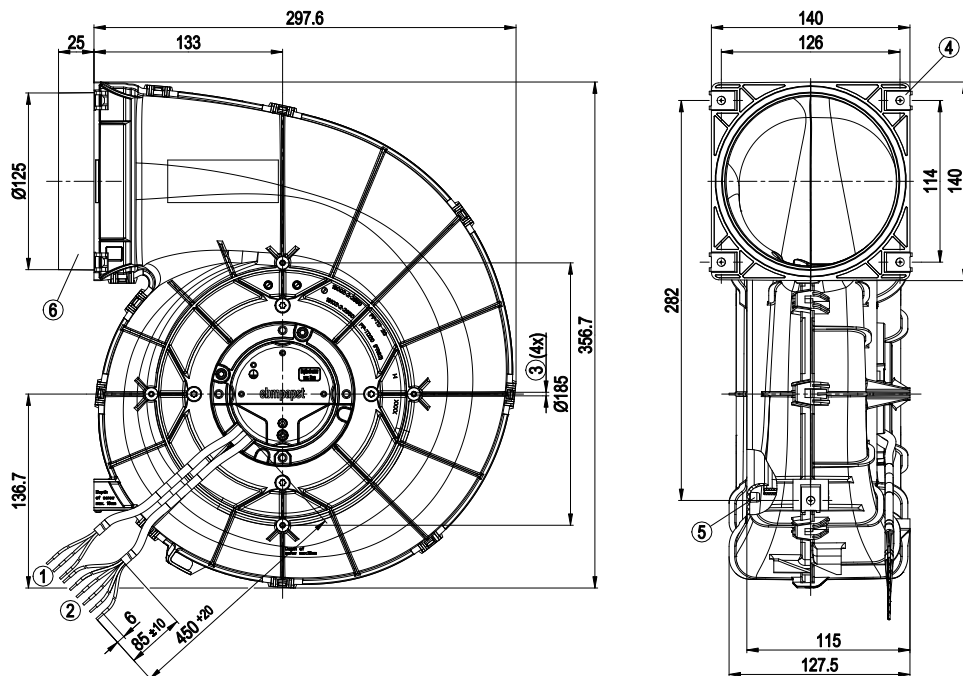

- ① Supply line (PWR) PVC AWG20, 3x splice
- ② Control wire (CTRL) PVC AWG22, 4x splice
- ③ Tapping hole prepared for self-tapping screw for fastening plastics (Remform) dia. 4 mm, clearance for screw max. 15 mm. The torque is to be determined on the basis of the screw.
- ④ 5x sheet metal nut for thread EN ISO 1478-ST4.8 (max. screw length 16 mm plus thickness of mounting material)
- ⑤ Screw-on domes are only permissible for Flowgrid!
- ⑥ Connecting sleeve not suitable for installation with pipe clamps

Pin assignment: See connection diagram
Mounting position: Any

RadiCal 220

EC centrifugal fans, backward curved



Material/Surface

- Impeller: PP plastic
- Rotor: Thick-film passivated
- Electronics housing: Die-cast aluminum

Mechanical characteristics

- Number of blades: 7
- Drehrichtung (epM): Clockwise, viewed toward rotor
- Installation position: Any
- Condensation drainage holes: None, open rotor
- Mode: S1
- Motor bearing: Ball bearing

Additional Information

- Information about touch current, electrical connection, degree of protection, insulation class, environmental protection class, EMC standards as well as standards and approvals can be found in the product-specific data sheets.

from page 32	Drawings
from page 58	Accessories
from page 66	Connection diagrams and technical equipment
from page 68	Environment and general conditions
More at	www.ebmpapst.com/worldwide www.ebmpapst.com/

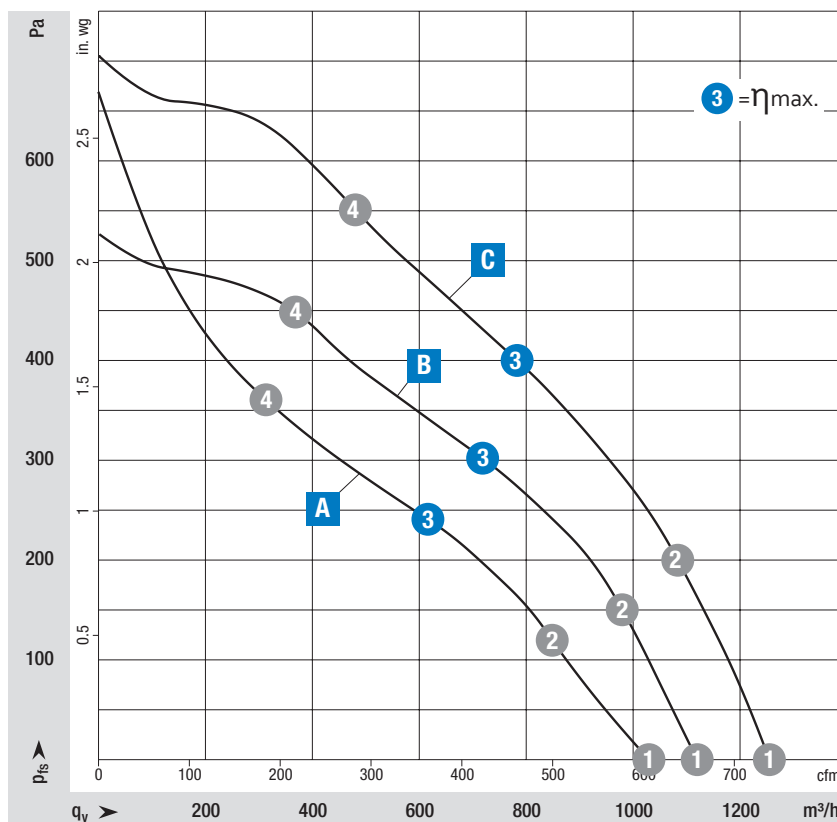



Measuring conditions

Air performance measured after: ISO 5801, installation category A, with ebm-papst inlet nozzle without contact protection.

Suction-side noise level: LwA according to ISO 13347, LpA measured at a distance of 1 m on the fan axis.

The specifications apply only under the specified measuring conditions and may change due to installation conditions.

In case of deviations from the standard design, the characteristic values must be checked in the installed condition!

Nominal voltage range 1- 200-240 VAC, 50/60 Hz			Characteristic Curve	Operating point	Nominal voltage	Speed n	Max. Input power P _{ed}	Max. Input current I	Sound power level LWA	Max. back pressure	Perm. ambient temp.	Protection class	Connection diagrams and technical equipment	
Type	Part number	Fan type			V	rpm	W	A	dB(A)	Pa	°C			
VBS0220RSLDS	8300100032	Centrifugal fan		A	1	230	2,860	85	0.70	74	---	-25...+60	IP54	Page 66
					2	230	2,690	85	0.70	69				
					3	230	2,550	85	0.70	66				
					4	230	2,685	85	0.70	71				
VBS0220RSLES	8300100072	Centrifugal fan		B	1	230	3,055	97	0.81	74	---	-25...+60	IP54	Page 66
					2	230	3,045	117	0.96	70				
					3	230	2,900	120	1.00	68				
					4	230	3,030	120	1.00	73				
VBS0220RSLFS	8300100212	Centrifugal fan		C	1	230	3,505	151	1.22	78	---	-25...+60	IP54	Page 66
					2	230	3,440	170	1.35	75				
					3	230	3,250	170	1.35	72				
					4	230	3,380	170	1.35	75				

Subject to changes.

Values set in blue are nominal data at the operating point at maximum load.

RadiCal 220

A VBS0220RSLDS 8300100032 EC centrifugal fan - RadiCal

Dimensions in mm

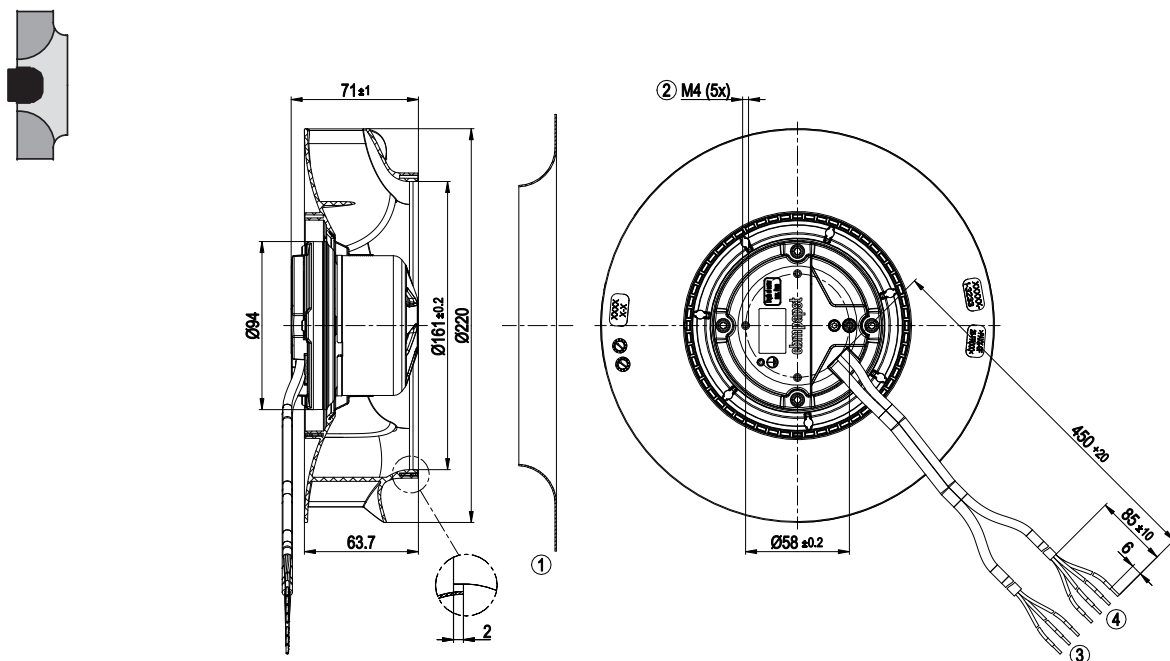

- ① Accessory part: inlet ring 09609-2-4013 not included in scope of delivery
- ② Max. clearance for screw 5 mm
- ③ Supply line (PWR) PVC AWG20, 3x splice
- ④ Control wire (CTRL) PVC AWG22, 4x splice

Pin assignment: See connection diagram
Mounting position: Any

B VBS0220RSLES 8300100072 EC centrifugal fan - RadiCal

Dimensions in mm

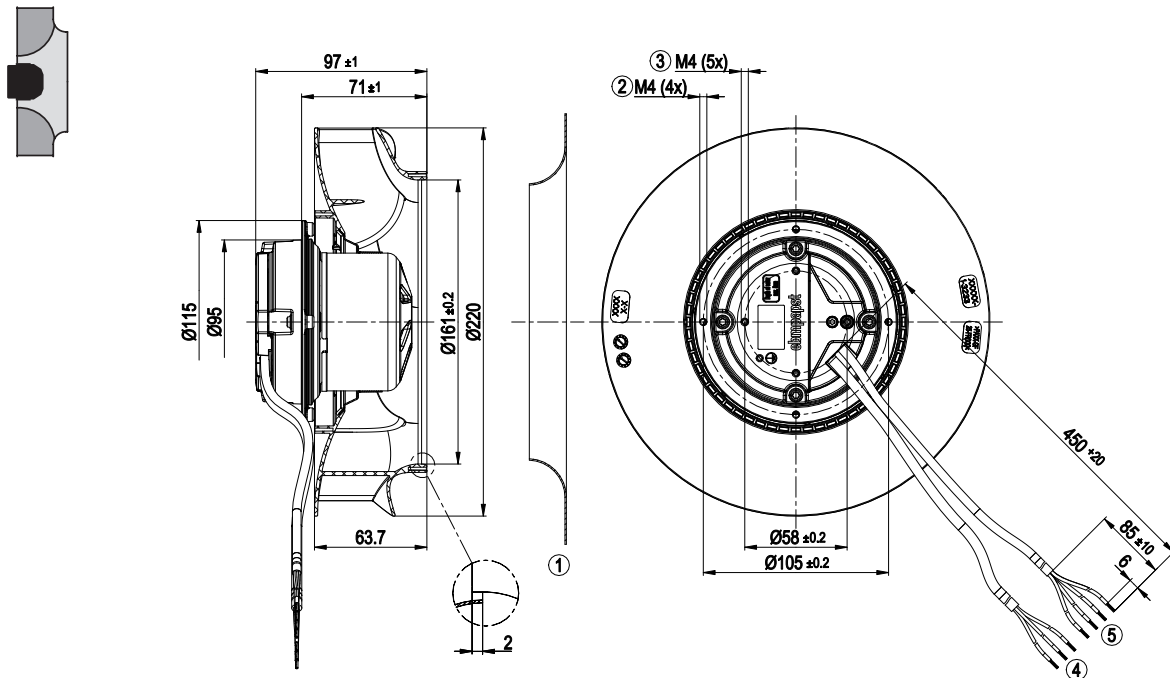

- ① Accessory part: Inlet ring 09609-2-4013 (not included in scope of delivery)
- ② Max. clearance for screw 6 mm
- ③ Max. clearance for screw 5 mm
- ④ Supply line (PWR) PVC AWG20, 3x splice
- ⑤ Control wire (CTRL) PVC AWG22, 4x splice

Pin assignment: See connection diagram
Mounting position: Any

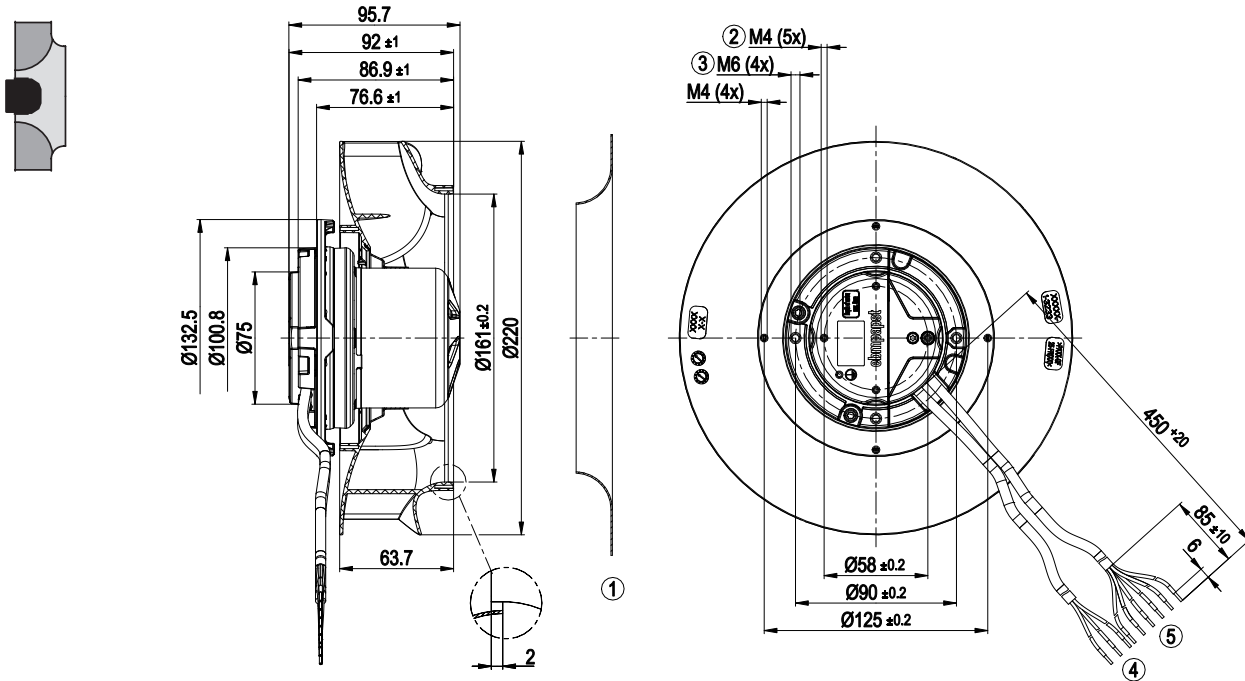

- ① Accessory part: inlet ring 09609-2-4013 not included in scope of delivery
- ② Max. clearance for screw 5 mm
- ③ Max. clearance for screw 10 mm
- ④ Supply line (PWR) PVC AWG20, 3x splice
- ⑤ Control wire (CTRL) PVC AWG22, 4x splice

Pin assignment: See connection diagram
Mounting position: Any

RadiCal 220

EC centrifugal modules, backward curved

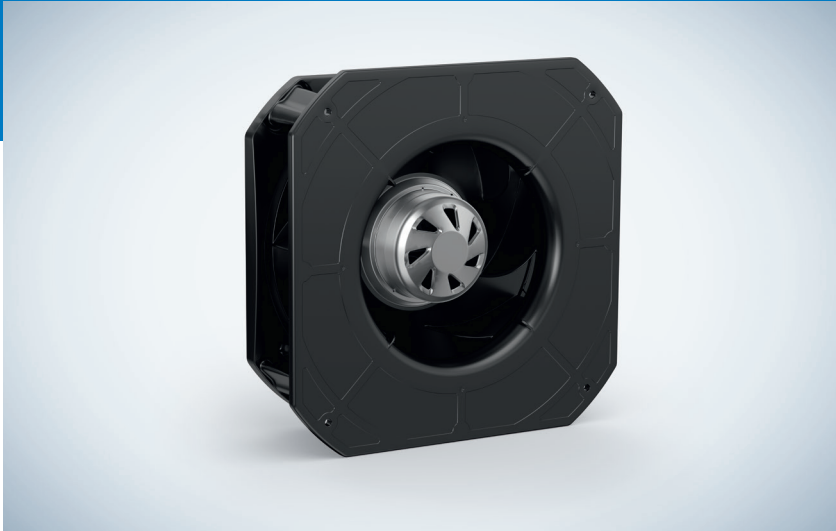

Material/Surface

- Impeller: PP plastic
- Rotor: Thick-film passivated
- Electronics housing: Die-cast aluminum

Mechanical characteristics

- Number of blades: 7
- Drehrichtung (epM): Clockwise, viewed toward rotor
- Installation position: Any
- Condensation drainage holes: None, open rotor
- Mode: S1
- Motor bearing: Ball bearing

Additional Information

- Information about touch current, electrical connection, degree of protection, insulation class, environmental protection class, EMC standards as well as standards and approvals can be found in the product-specific data sheets.

from page 36	Drawings
from page 58	Accessories
from page 66	Connection diagrams and technical equipment
from page 68	Environment and general conditions
More at	www.ebmpapst.com/worldwide www.ebmpapst.com/

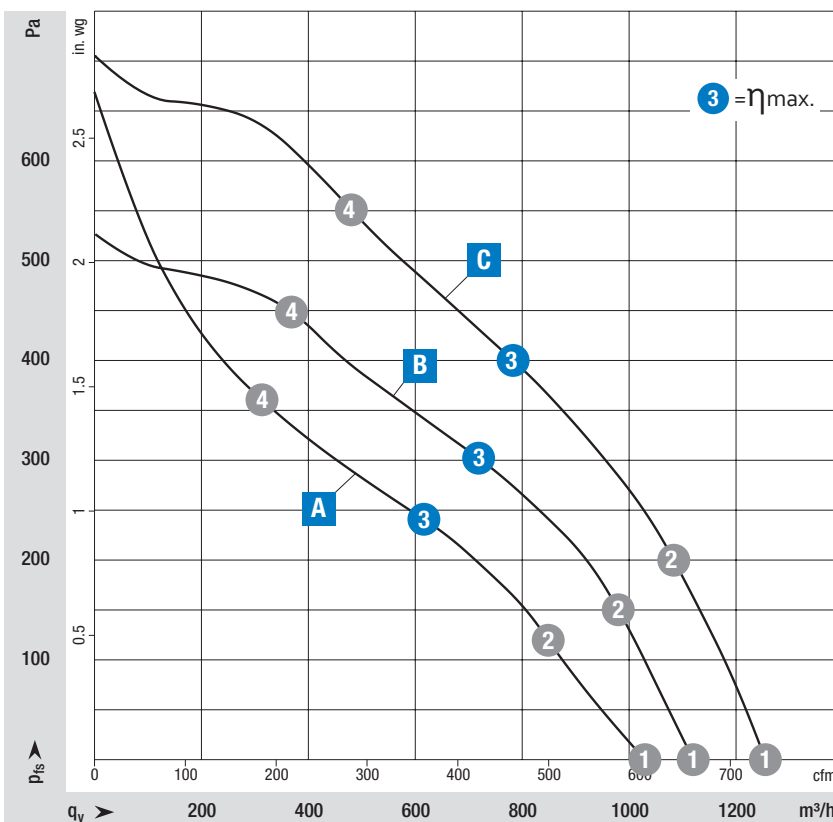



Measuring conditions

Air performance measured after: ISO 5801, installation category A, with ebm-papst inlet nozzle without contact protection.

Suction-side noise level: LwA according to ISO 13347, LpA measured at a distance of 1 m on the fan axis.

The specifications apply only under the specified measuring conditions and may change due to installation conditions.

In case of deviations from the standard design, the characteristic values must be checked in the installed condition!

Nominal voltage range 1- 200-240 VAC, 50/60 Hz			Characteristic Curve	Operating point	Nominal voltage	Speed n	Max. Input power P _{ed}	Max. Input current I	Sound power level L _{WA}	Max. back pressure	Perm. ambient temp.	Protection class	Connection diagrams and technical equipment	
Type	Part number	Fan type			V	rpm	W	A	dB(A)	Pa	°C			
VBH0220RSLDS	8300100033	Centrifugal module		A	①	230	2,860	85	0.70	74	---	-25...+60	IP54	Page 66
					②	230	2,690	85	0.70	69				
					③	230	2,550	85	0.70	66				
					④	230	2,685	85	0.70	71				
VBH0220RSLES	8300100071	Centrifugal module		B	①	230	3,055	97	0.81	74	---	-25...+60	IP54	Page 66
					②	230	3,045	117	0.96	70				
					③	230	2,900	120	1.00	68				
					④	230	3,030	120	1.00	73				
VBH0220RSLFS	8300100282	Centrifugal module		C	①	230	3,505	151	1.22	78	---	-25...+60	IP54	Page 66
					②	230	3,440	170	1.35	75				
					③	230	3,250	170	1.35	72				
					④	230	3,380	170	1.35	75				

Subject to changes.

Values set in blue are nominal data at the operating point at maximum load.

RadiCal 220

A VBH0220RSLDS 8300100033 EC centrifugal module - RadiCal

Dimensions in mm

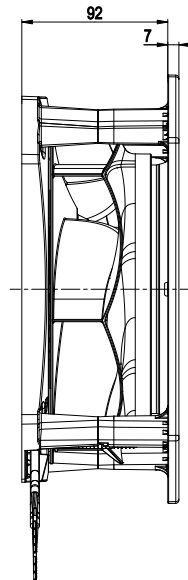
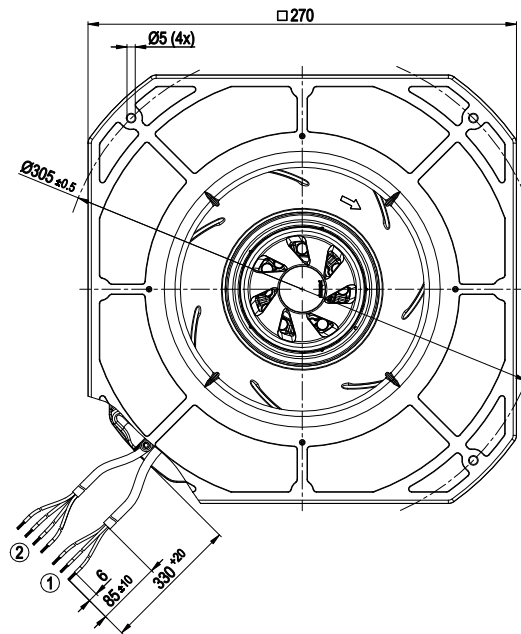

- ① Supply line (PWR) PVC AWG20, 3x splice
- ② Control wire (CTRL) PVC AWG22, 4x splice

Pin assignment: See connection diagram
Mounting position: Any

B VBH0220RSLES 8300100071 EC centrifugal module - RadiCal

Dimensions in mm

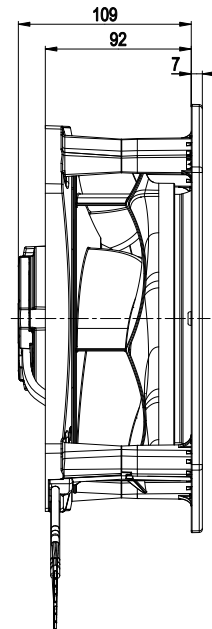
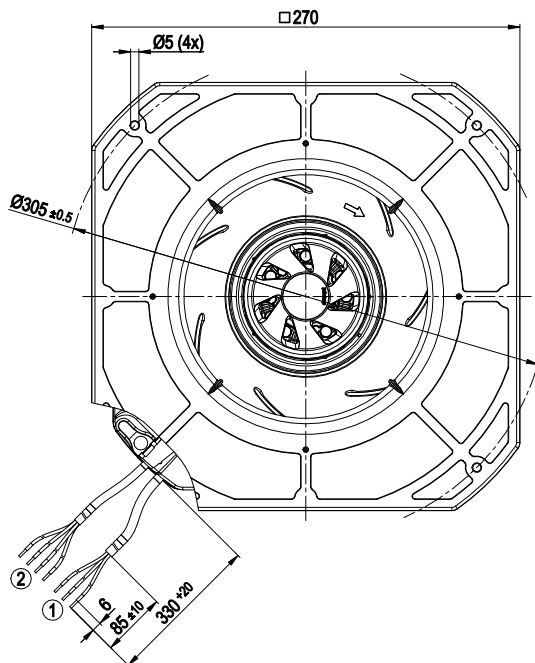

- ① Supply line (PWR) PVC AWG20, 3x splice
- ② Control wire (CTRL) PVC AWG22, 4x splice

Pin assignment: See connection diagram
Mounting position: Any

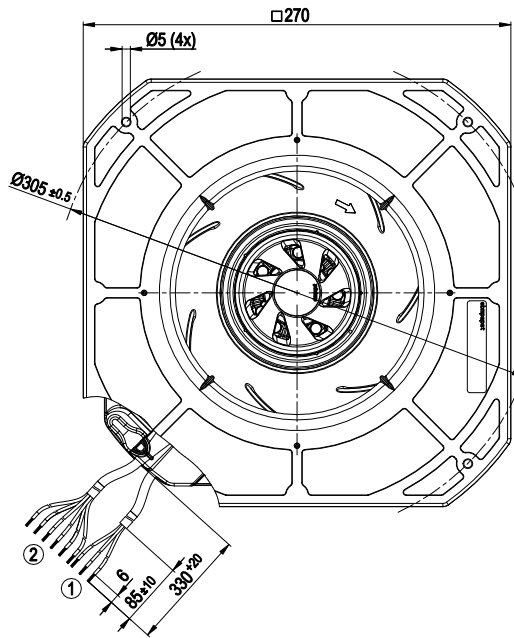

- ① Supply line (PWR) PVC AWG20, 3x splice
- ② Control wire (CTRL) PVC AWG22, 4x splice

Pin assignment: See connection diagram
Mounting position: Any

RadiCal 225

EC centrifugal fans, backward curved



Material/Surface

- Impeller: PP plastic
- Rotor: Thick-film passivated
- Electronics housing: Die-cast aluminum

Mechanical characteristics

- Number of blades: 7
- Drehrichtung (epM): Clockwise, viewed toward rotor
- Installation position: Any
- Condensation drainage holes: None, open rotor
- Mode: S1
- Motor bearing: Ball bearing

Additional Information

- Information about touch current, electrical connection, degree of protection, insulation class, environmental protection class, EMC standards as well as standards and approvals can be found in the product-specific data sheets.

from page 40	Drawings
from page 58	Accessories
from page 66	Connection diagrams and technical equipment
from page 68	Environment and general conditions
More at	www.ebmpapst.com/worldwide www.ebmpapst.com/

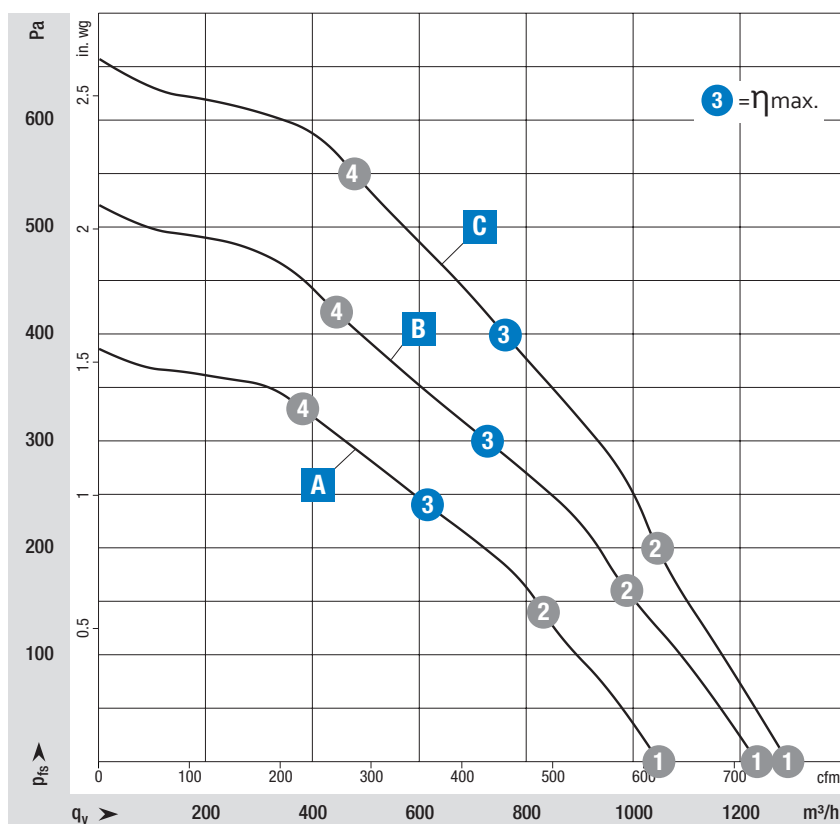



Measuring conditions

Air performance measured after: ISO 5801, installation category A, with ebm-papst inlet nozzle without contact protection.

Suction-side noise level: LwA according to ISO 13347, LpA measured at a distance of 1 m on the fan axis.

The specifications apply only under the specified measuring conditions and may change due to installation conditions.

In case of deviations from the standard design, the characteristic values must be checked in the installed condition!

Nominal voltage range 1- 200-240 VAC, 50/60 Hz			Characteristic Curve	Operating point	Nominal voltage	Speed n	Max. Input power P _{ed}	Max. Input current I	Sound power level L _{WA}	Max. back pressure	Perm. ambient temp.	Protection class	Connection diagrams and technical equipment	
Type	Part number	Fan type			V	rpm	W	A	dB(A)	Pa	°C			
VBS0225RSLDS	8300100296	Centrifugal fan		A	1	230	2,410	79	0.65	72	---	-25...+60	IP54	Page 66
					2	230	2,270	85	0.70	67				
					3	230	2,250	85	0.70	62				
					4	230	2,345	85	0.70	66				
VBS0225RSLES	8300100169	Centrifugal fan		B	1	230	2,750	113	0.93	75	---	-25...+60	IP54	Page 66
					2	230	2,565	120	1.00	70				
					3	230	2,500	120	1.00	65				
					4	230	2,635	120	1.00	70				
VBS0225RSLFS	8300100167	Centrifugal fan		C	1	230	3,110	170	1.35	81	---	-25...+60	IP54	Page 66
					2	230	2,915	170	1.35	75				
					3	230	2,850	170	1.35	70				
					4	230	3,025	170	1.35	74				

Subject to changes.

Values set in blue are nominal data at the operating point at maximum load.

RadiCal 225

A VBS0225RSLDS 8300100296 EC centrifugal fan - RadiCal

Dimensions in mm

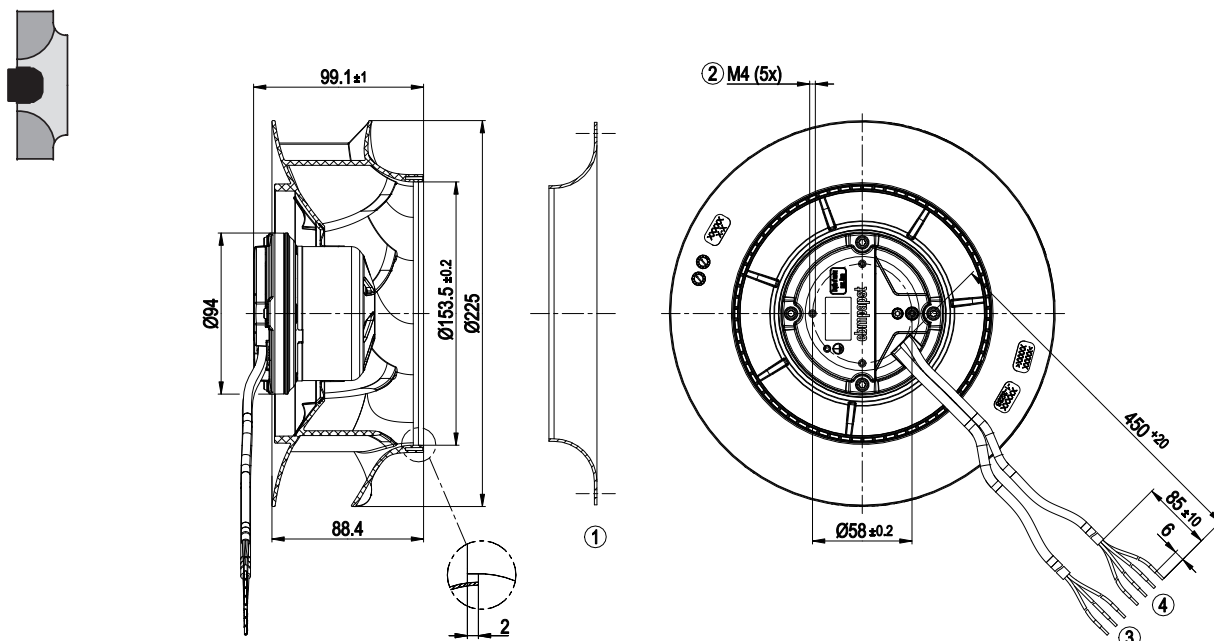

- ① Accessory part: inlet ring 96358-2-4013 not included in scope of delivery
- ② Max. clearance for screw 5 mm
- ③ Supply line (PWR) PVC AWG20, 3x splice
- ④ Control wire (CTRL) PVC AWG22, 4x splice

Pin assignment: See connection diagram
Mounting position: Any

B VBS0225RSLES 8300100169 EC centrifugal fan - RadiCal

Dimensions in mm

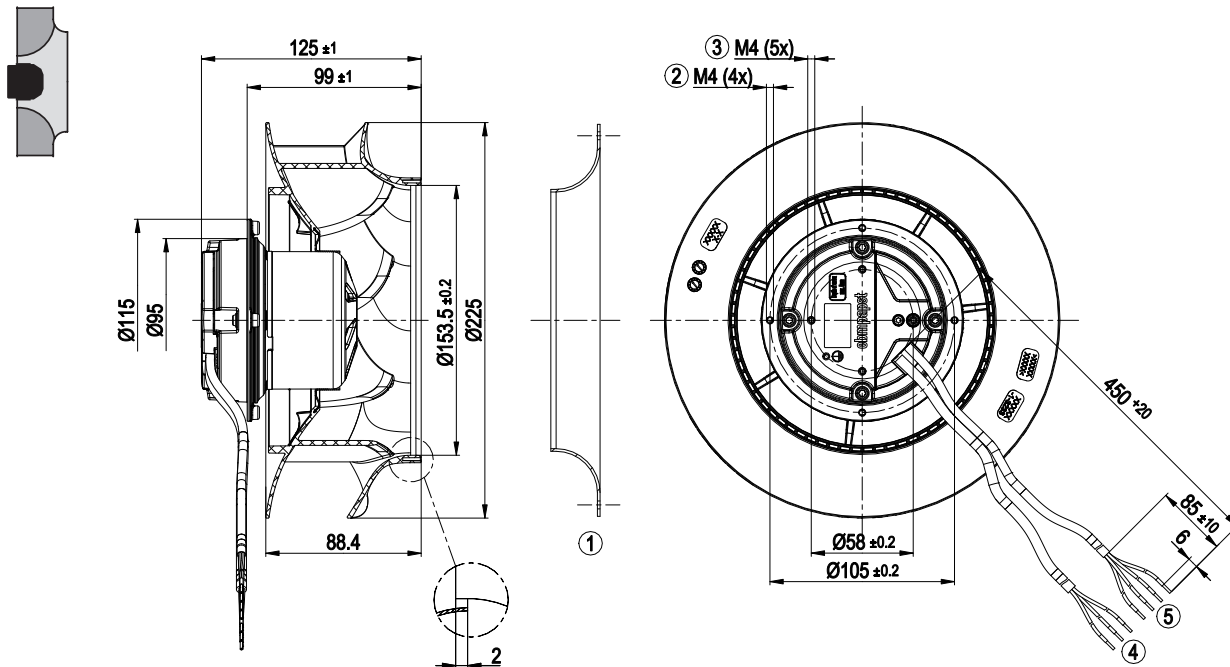

- ① Accessory part: inlet ring 96358-2-4013 not included in scope of delivery
- ② Max. clearance for screw 6 mm
- ③ Max. clearance for screw 5 mm
- ④ Supply line (PWR) PVC AWG20, 3x splice
- ⑤ Control wire (CTRL) PVC AWG22, 4x splice

Pin assignment: See connection diagram
Mounting position: Any

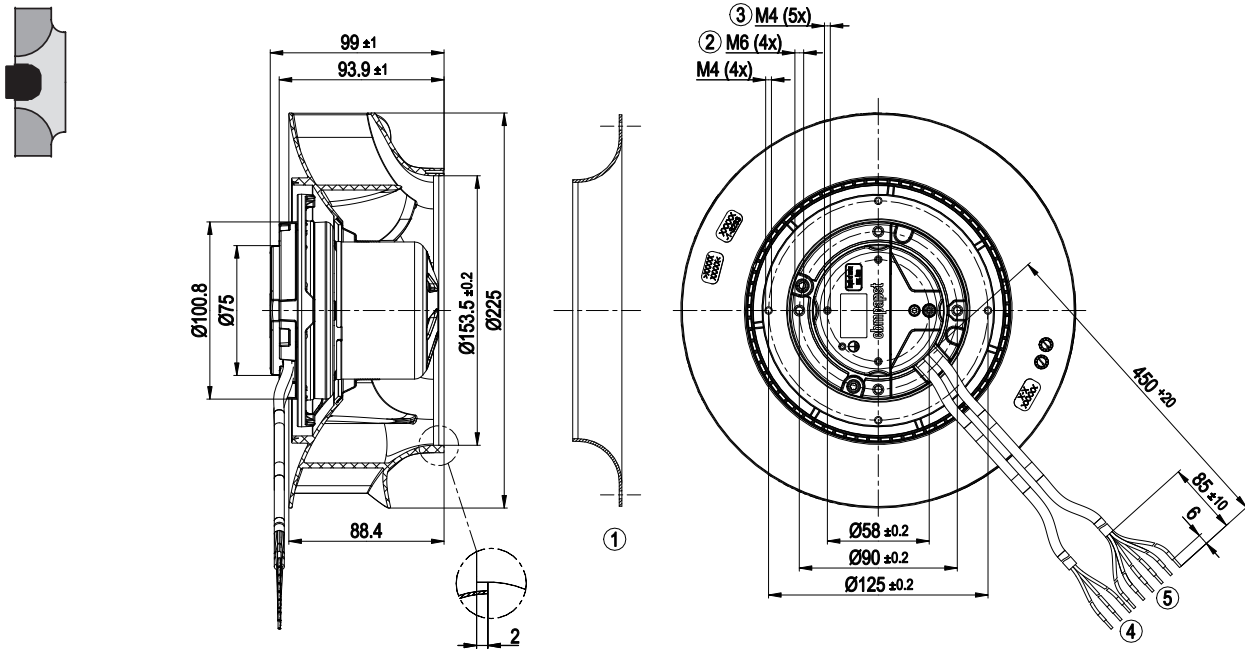

- ① Accessory part: inlet ring 96358-2-4013 not included in scope of delivery
- ② Max. clearance for screw 10 mm
- ③ Max. clearance for screw 5 mm
- ④ Supply line (PWR) PVC AWG20, 3x splice
- ⑤ Control wire (CTRL) PVC AWG22, 4x splice

Pin assignment: See connection diagram
Mounting position: Any

RadiCal 225

EC centrifugal modules, backward curved



Material/Surface

- Impeller: PP plastic
- Rotor: Thick-film passivated
- Electronics housing: Die-cast aluminum

Mechanical characteristics

- Number of blades: 7
- Drehrichtung (epM): Clockwise, viewed toward rotor
- Installation position: Any
- Condensation drainage holes: None, open rotor
- Mode: S1
- Motor bearing: Ball bearing

Additional Information

- Information about touch current, electrical connection, degree of protection, insulation class, environmental protection class, EMC standards as well as standards and approvals can be found in the product-specific data sheets.

from page 44	Drawings
from page 58	Accessories
from page 66	Connection diagrams and technical equipment
from page 68	Environment and general conditions
More at	www.ebmpapst.com/worldwide www.ebmpapst.com/

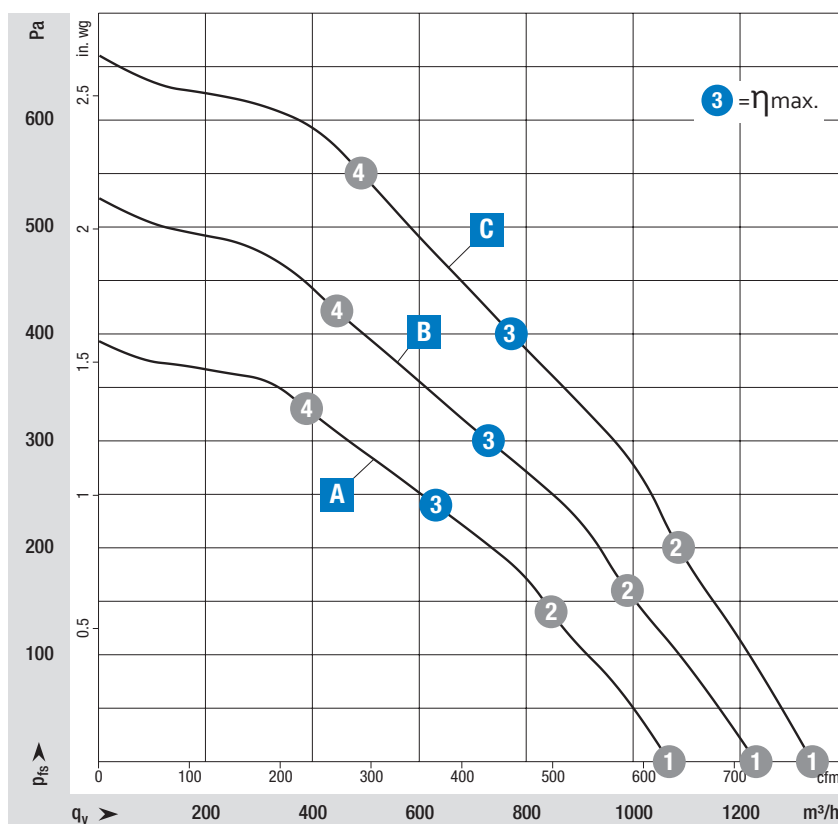



Measuring conditions

Air performance measured after: ISO 5801, installation category A, with ebm-papst inlet nozzle without contact protection.

Suction-side noise level: LwA according to ISO 13347, LpA measured at a distance of 1 m on the fan axis.

The specifications apply only under the specified measuring conditions and may change due to installation conditions.

In case of deviations from the standard design, the characteristic values must be checked in the installed condition!

Nominal voltage range 1- 200-240 VAC, 50/60 Hz			Characteristic Curve	Operating point	Nominal voltage	Speed n	Max. Input power P _{ed}	Max. Input current I	Sound power level L _{WA}	Max. back pressure	Perm. ambient temp.	Protection class	Connection diagrams and technical equipment	
Type	Part number	Fan type			V	rpm	W	A	dB(A)	Pa	°C			
VBH0225RSLDS	8300100295	Centrifugal module		A	①	230	2,410	80	0.65	73	---	-25...+60	IP54	Page 66
					②	230	2,280	85	0.70	67				
					③	230	2,250	85	0.70	63				
					④	230	2,360	85	0.70	67				
VBH0225RSLES	8300100173	Centrifugal module		B	①	230	2,750	114	0.93	76	---	-25...+60	IP54	Page 66
					②	230	2,565	120	1.00	70				
					③	230	2,500	120	1.00	65				
					④	230	2,625	120	1.00	70				
VBH0225RSLFS	8300100170	Centrifugal module		C	①	230	3,080	163	1.29	79	---	-25...+60	IP54	Page 66
					②	230	2,895	170	1.35	74				
					③	230	2,850	170	1.35	69				
					④	230	2,970	170	1.35	74				

Subject to changes.

Values set in blue are nominal data at the operating point at maximum load.

RadiCal 225

A VBH0225RSLDS 8300100295 EC centrifugal module - RadiCal

Dimensions in mm

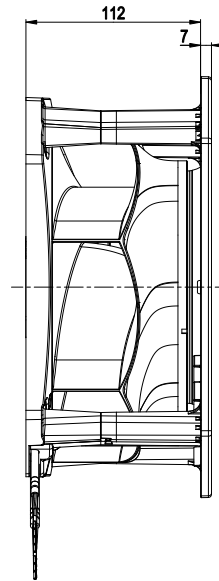
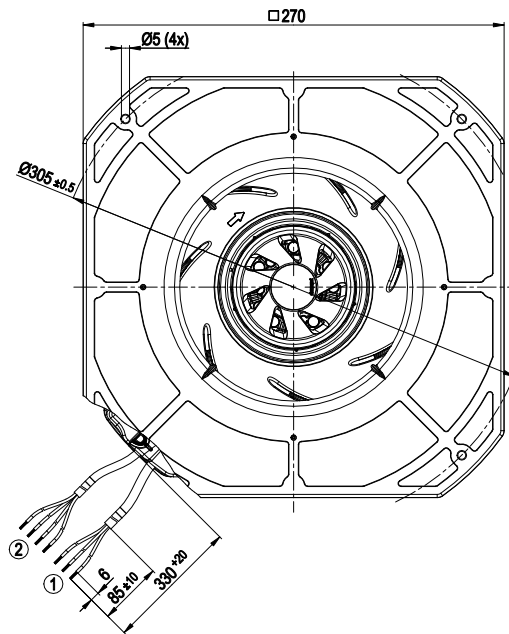

- ① Supply line (PWR) PVC AWG20, 3x splice
- ② Control wire (CTRL) PVC AWG22, 4x splice

Pin assignment: See connection diagram
Mounting position: Any

B VBH0225RSLES 8300100173 EC centrifugal module

Dimensions in mm

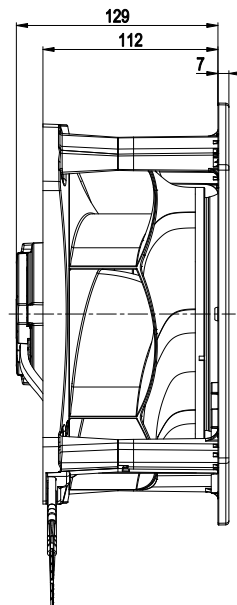
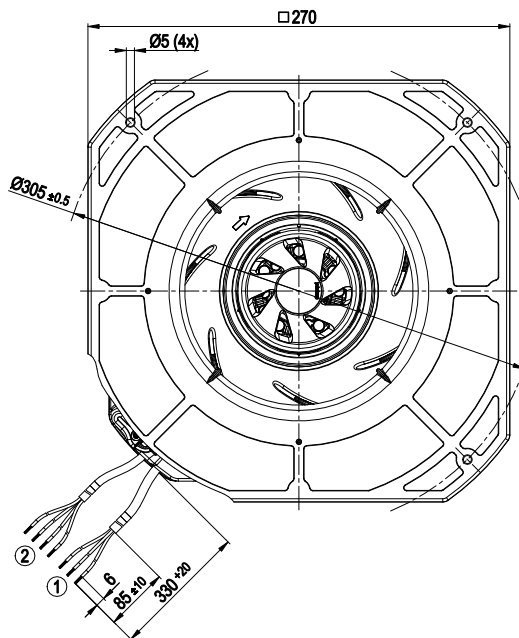

- ① Supply line (PWR) PVC AWG20, 3x splice
- ② Control wire (CTRL) PVC AWG22, 4x splice

Pin assignment: See connection diagram
Mounting position: Any

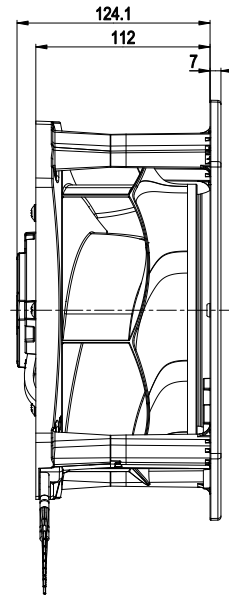
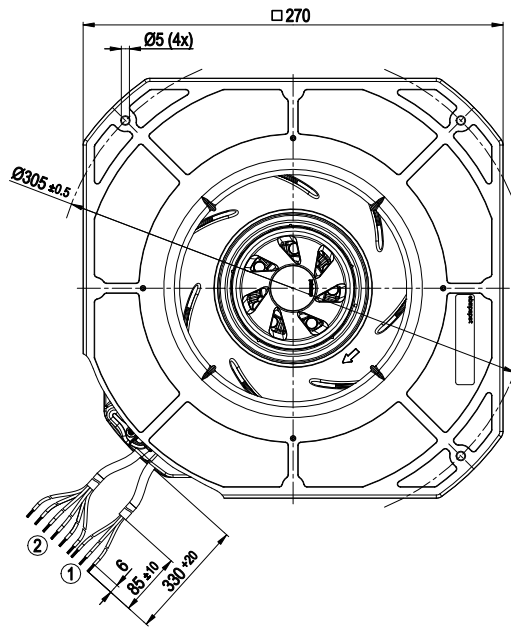

- ① Supply line (PWR) PVC AWG20, 3x splice
- ② Control wire (CTRL) PVC AWG22, 4x splice

Pin assignment: See connection diagram
Mounting position: Any

RadiCal 225

EC centrifugal fans, backward curved with housing



Material/Surface

- Impeller: PP plastic
- Rotor: Thick-film passivated

Mechanical characteristics

- Number of blades: 7
- Drehrichtung (epM): Clockwise, viewed toward rotor
- Installation position: Any
- Condensation drainage holes: None, open rotor
- Mode: S1
- Motor bearing: Ball bearing

Additional Information

- Information about touch current, electrical connection, degree of protection, insulation class, environmental protection class, EMC standards as well as standards and approvals can be found in the product-specific data sheets.

from page 48	Drawings
from page 58	Accessories
from page 66	Connection diagrams and technical equipment
from page 68	Environment and general conditions
More at	www.ebmpapst.com/worldwide www.ebmpapst.com/

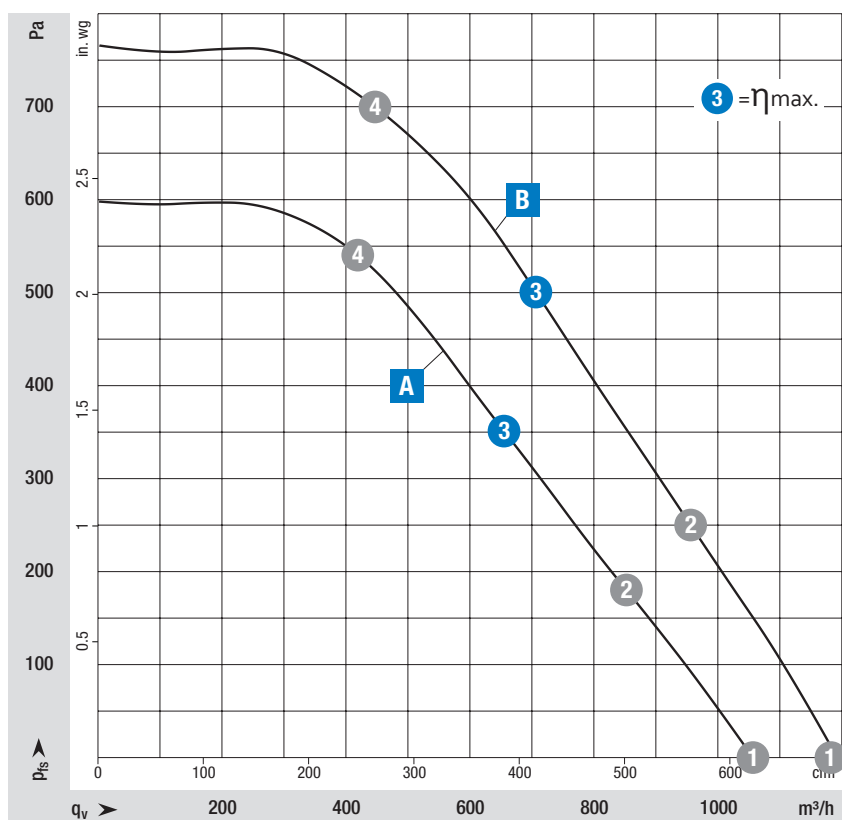



Measuring conditions

Air performance measured after: ISO 5801, installation category A, with ebm-papst inlet nozzle without contact protection.

Suction-side noise level: LwA according to ISO 13347, LpA measured at a distance of 1 m on the fan axis.

The specifications apply only under the specified measuring conditions and may change due to installation conditions.

In case of deviations from the standard design, the characteristic values must be checked in the installed condition!

Nominal voltage range 1- 200-240 VAC, 50/60 Hz			Characteristic Curve	Operating point	Nominal voltage	Speed n	Max. Input power P _{ed}	Max. Input current I	Sound power level LWA	Max. back pressure	Perm. ambient temp.	Protection class	Connection diagrams and technical equipment	
Type	Part number	Fan type			V	rpm	W	A	dB(A)	Pa	°C			
VCS0225RSLES	8300100470	Centrifugal fan with housing		A	1	230	2,655	117	0.97	75	---	-25...+60	IP54	Page 66
					2	230	2,560	120	1.00	71				
					3	230	2,500	120	1.00	69				
					4	230	2,655	113	0.95	70				
VCS0225RSLFS	8300100439	Centrifugal fan with housing		B	1	230	3,000	162	1.32	77	---	-25...+60	IP54	Page 66
					2	230	2,925	170	1.35	73				
					3	230	2,900	170	1.35	70				
					4	230	3,000	154	1.27	73				

Subject to changes.

Values set in blue are nominal data at the operating point at maximum load.

RadiCal 225

A VCS0225RSLES 8300100470 EC centrifugal fan - RadiCal with housing

Dimensions in mm

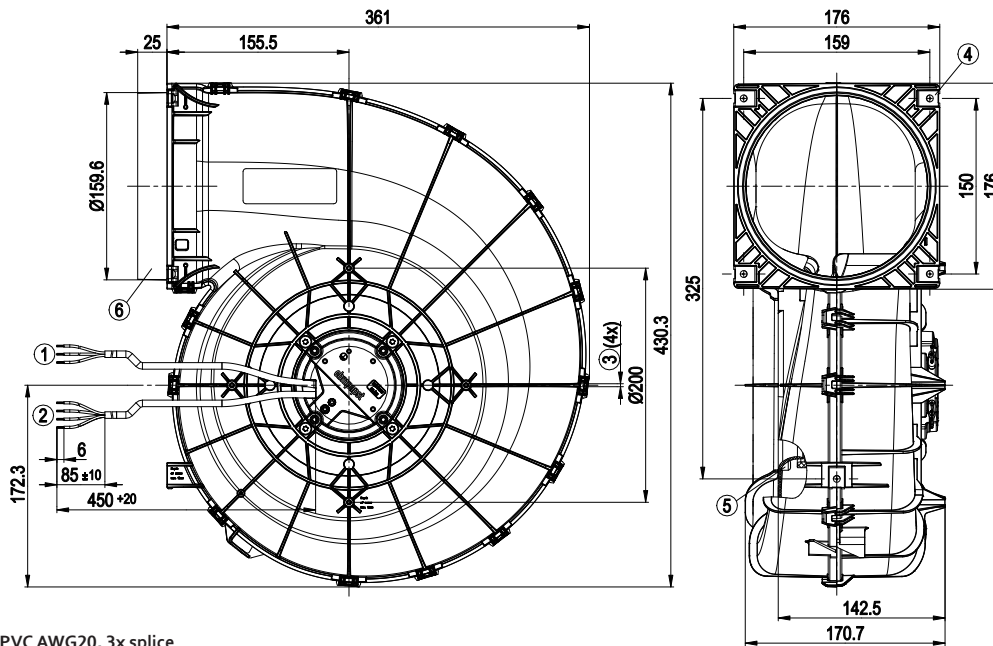

- ① Supply line (PWR) PVC AWG20, 3x splice
- ② Control wire (CTRL) PVC AWG22, 4x splice
- ③ Tapping hole prepared for self-tapping screw for fastening plastics (Remform) dia. 4 mm, clearance for screw max. 15 mm. The torque is to be determined on the basis of the screw.
- ④ 5x sheet metal nut for thread EN ISO 1478-ST4.8 (max. screw length 16 mm plus thickness of mounting material)
- ⑤ Screw-on domes are only permissible for Flowgrid!
- ⑥ Connecting sleeve not suitable for installation with pipe clamps

Pin assignment: See connection diagram
Mounting position: Any

B VCS0225RSLFS 8300100439 EC centrifugal fan - RadiCal with housing

Dimensions in mm

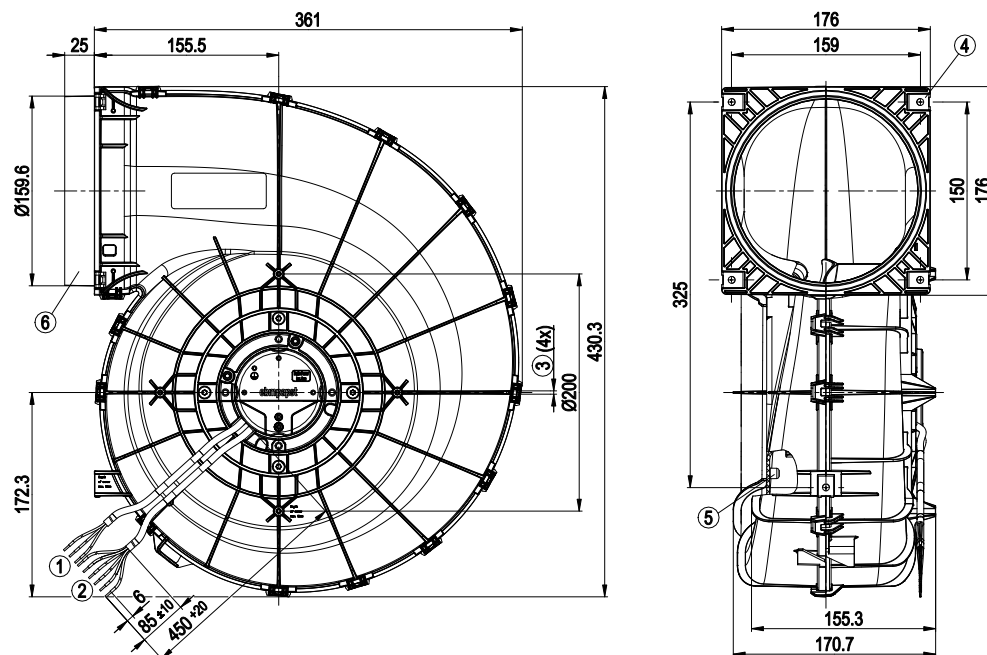

- ① Supply line (PWR) PVC AWG20, 3x splice
- ② Control wire (CTRL) PVC AWG22, 4x splice
- ③ Tapping hole prepared for self-tapping screw for fastening plastics (Remform) dia. 4 mm, clearance for screw max. 15 mm. The torque is to be determined on the basis of the screw.
- ④ 5x sheet metal nut for thread EN ISO 1478-ST4.8 (max. screw length 16 mm plus thickness of mounting material)
- ⑤ Screw-on domes are only permissible for Flowgrid!
- ⑥ Connecting sleeve not suitable for installation with pipe clamps

Pin assignment: See connection diagram
Mounting position: Any

RadiCal 250

EC centrifugal fans, backward curved



Material/Surface

- Impeller: PA plastic
- Rotor: Thick-film passivated
- Electronics housing: Die-cast aluminum

Mechanical characteristics

- Number of blades: 7
- Drehrichtung (epM): Clockwise, viewed toward rotor
- Installation position: Any
- Condensation drainage holes: None, open rotor
- Mode: S1
- Motor bearing: Ball bearing

Additional Information

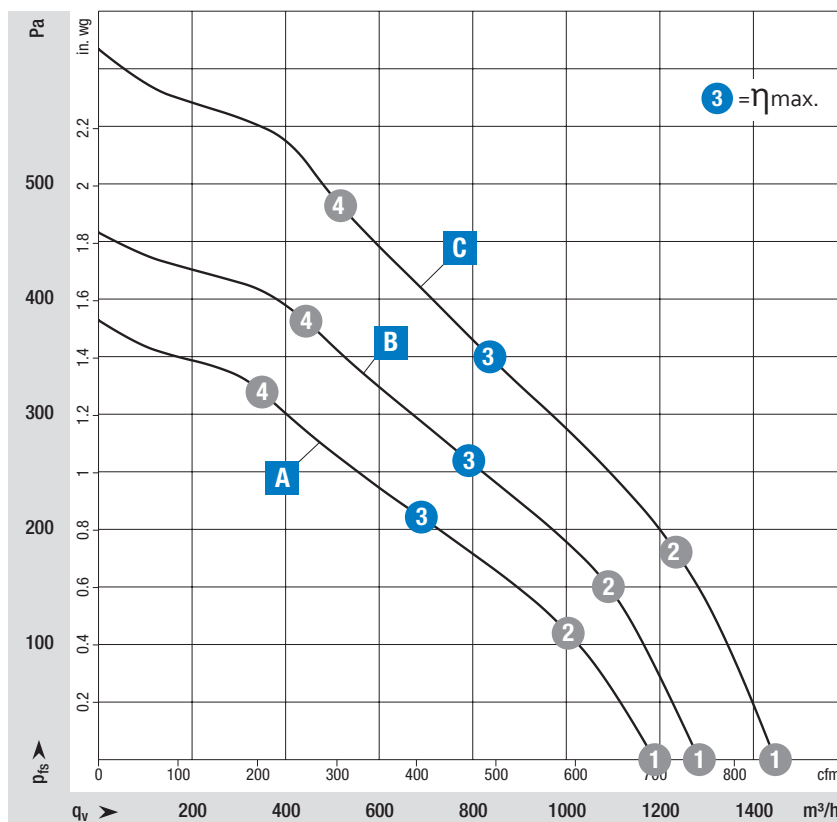

- Information about touch current, electrical connection, degree of protection, insulation class, environmental protection class, EMC standards as well as standards and approvals can be found in the product-specific data sheets.

from page 52	Drawings
from page 58	Accessories
from page 66	Connection diagrams and technical equipment
from page 68	Environment and general conditions
More at	www.ebmpapst.com/worldwide www.ebmpapst.com/



Measuring conditions

Air performance measured after: ISO 5801, installation category A, with ebm-papst inlet nozzle without contact protection.
Suction-side noise level: LwA according to ISO 13347, LpA measured at a distance of 1 m on the fan axis.
The specifications apply only under the specified measuring conditions and may change due to installation conditions.
In case of deviations from the standard design, the characteristic values must be checked in the installed condition!

Nominal voltage range 1- 200-240 VAC, 50/60 Hz			Characteristic Curve	Operating point	Nominal voltage	Speed n	Max. Input power P _{ed}	Max. Input current I	Sound power level L _{WA}	Max. back pressure	Perm. ambient temp.	Protection class	Connection diagrams and technical equipment	
Type	Part number	Fan type			V	rpm	W	A	dB(A)	Pa	°C			
VBS0250RSLES	8300100227	Centrifugal fan		A	①	230	2,155	75	0.62	72	---	-25...+60	IP54	Page 66
					②	230	2,095	85	0.70	67				
					③	230	2,000	85	0.70	62				
					④	230	2,120	85	0.70	67				
VBS0250RSLFS	8300100219	Centrifugal fan		B	①	230	2,355	98	0.81	73	---	-25...+60	IP54	Page 66
					②	230	2,325	120	1.00	69				
					③	230	2,200	120	1.00	65				
					④	230	2,315	120	1.00	69				
VBS0250RSLFS	8300100178	Centrifugal fan		C	①	230	2,705	149	1.20	77	---	-25...+60	IP54	Page 66
					②	230	2,640	170	1.35	72				
					③	230	2,550	170	1.35	68				
					④	230	2,615	170	1.35	72				

Subject to changes.

Values set in blue are nominal data at the operating point at maximum load.

RadiCal 250

A VBS0250RSLES 8300100227 EC centrifugal fan - RadiCal

Dimensions in mm

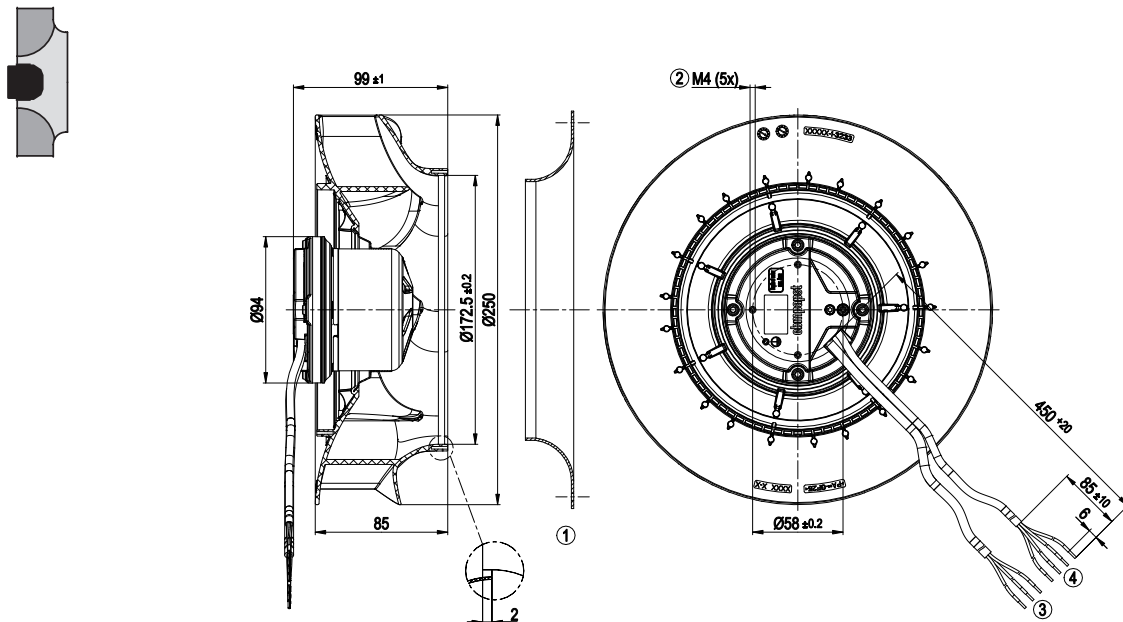

- ① Accessory part: inlet ring 96359-2-4013 not included in scope of delivery
- ② Max. clearance for screw 5 mm
- ③ Supply line (PWR) PVC AWG20, 3x splice
- ④ Control wire (CTRL) PVC AWG22, 4x splice

Pin assignment: See connection diagram
Mounting position: Any

B VBS0250RSLFS 8300100219 EC centrifugal fan - RadiCal

Dimensions in mm

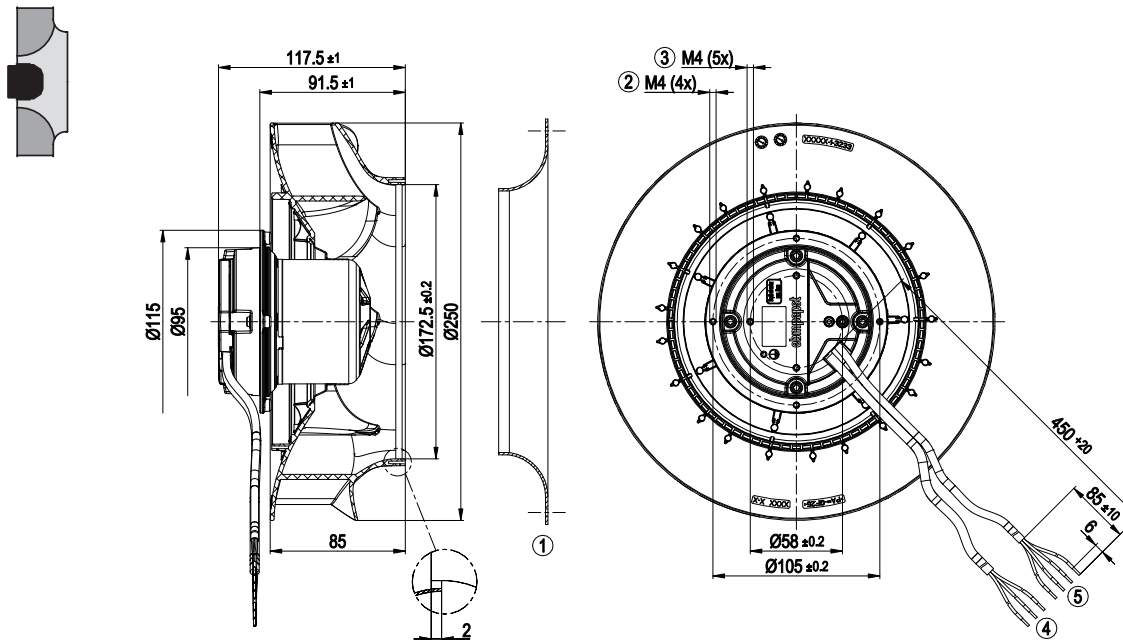

- ① Accessory part: inlet ring 96359-2-4013 not included in scope of delivery
- ② Max. clearance for screw 6 mm
- ③ Max. clearance for screw 5 mm
- ④ Supply line (PWR) PVC AWG20, 3x splice
- ⑤ Control wire (CTRL) PVC AWG22, 4x splice

Pin assignment: See connection diagram
Mounting position: Any

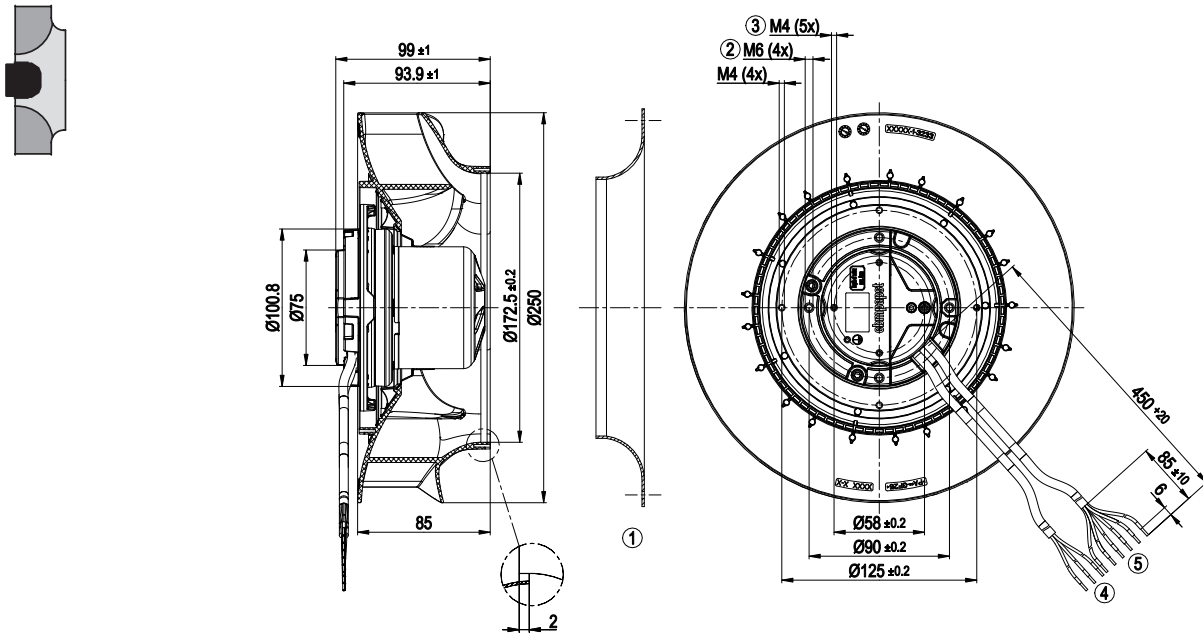

- ① Accessory part: inlet ring 96359-2-4013 not included in scope of delivery
- ② Max. clearance for screw 10 mm
- ③ Max. clearance for screw 5 mm
- ④ Supply line (PWR) PVC AWG20, 3x splice
- ⑤ Control wire (CTRL) PVC AWG22, 4x splice

Pin assignment: See connection diagram
Mounting position: Any

RadiCal 250

EC centrifugal modules, backward curved



Material/Surface

- Impeller: PA plastic
- Rotor: Thick-film passivated
- Electronics housing: Die-cast aluminum

Mechanical characteristics

- Number of blades: 7
- Drehrichtung (epM): Clockwise, viewed toward rotor
- Installation position: Any
- Condensation drainage holes: None, open rotor
- Mode: S1
- Motor bearing: Ball bearing

Additional Information

- Information about touch current, electrical connection, degree of protection, insulation class, environmental protection class, EMC standards as well as standards and approvals can be found in the product-specific data sheets.

from page 56	Drawings
from page 58	Accessories
from page 66	Connection diagrams and technical equipment
from page 68	Environment and general conditions
More at	www.ebmpapst.com/worldwide www.ebmpapst.com/

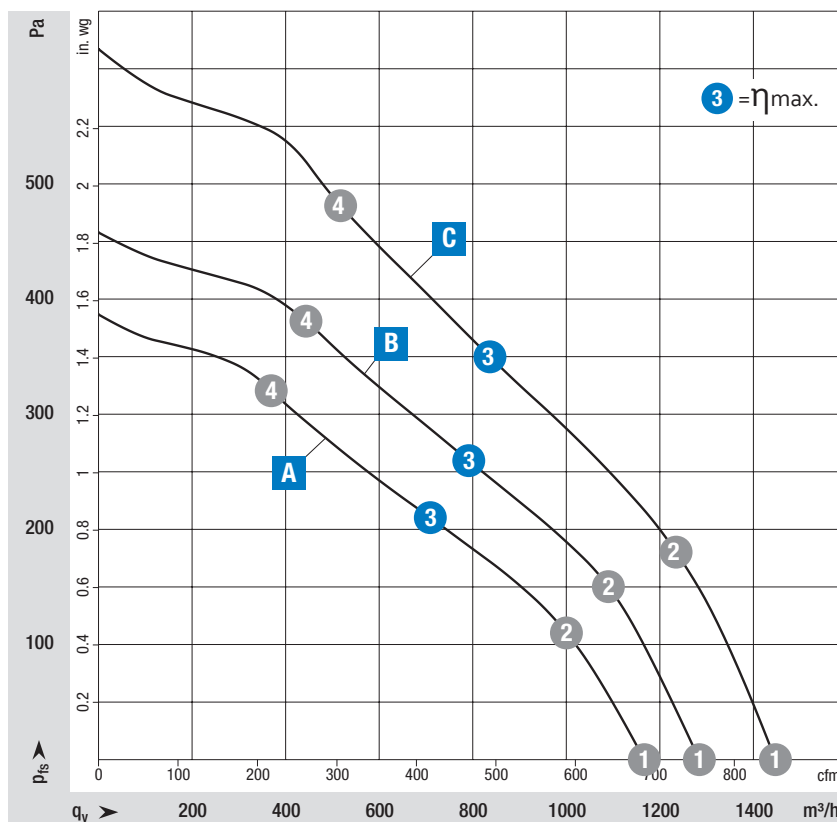



Measuring conditions

Air performance measured after: ISO 5801, installation category A, with ebm-papst inlet nozzle without contact protection.

Suction-side noise level: LwA according to ISO 13347, LpA measured at a distance of 1 m on the fan axis.

The specifications apply only under the specified measuring conditions and may change due to installation conditions.

In case of deviations from the standard design, the characteristic values must be checked in the installed condition!

Nominal voltage range 1- 200-240 VAC, 50/60 Hz			Characteristic Curve	Operating point	Nominal voltage	Speed n	Max. Input power P _{ed}	Max. Input current I	Sound power level LWA	Max. back pressure	Perm. ambient temp.	Protection class	Connection diagrams and technical equipment	
Type	Part number	Fan type			V	rpm	W	A	dB(A)	Pa	°C			
VBH0250RSLES	8300100228	Centrifugal module		A	1	230	2,165	75	0.61	71	---	-25...+60	IP54	Page 66
					2	230	2,105	85	0.70	66				
					3	230	2,000	85	0.70	62				
					4	230	2,110	85	0.70	67				
VBH0250RSLFS	8300100185	Centrifugal module		B	1	230	2,355	98	0.81	73	---	-25...+60	IP54	Page 66
					2	230	2,325	120	1.00	69				
					3	230	2,200	120	1.00	65				
					4	230	2,315	120	1.00	69				
VBH0250RSLFS	8300100177	Centrifugal module		C	1	230	2,705	149	1.20	77	---	-25...+60	IP54	Page 66
					2	230	2,640	170	1.35	72				
					3	230	2,550	170	1.35	68				
					4	230	2,615	170	1.35	72				

Subject to changes.

Values set in blue are nominal data at the operating point at maximum load.

RadiCal 250

A VBH0250RSLES 8300100228 EC centrifugal module - RadiCal

Dimensions in mm

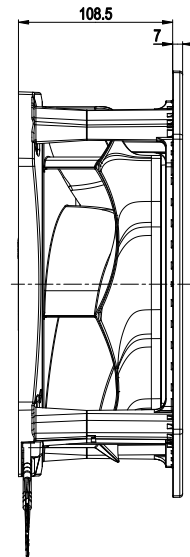
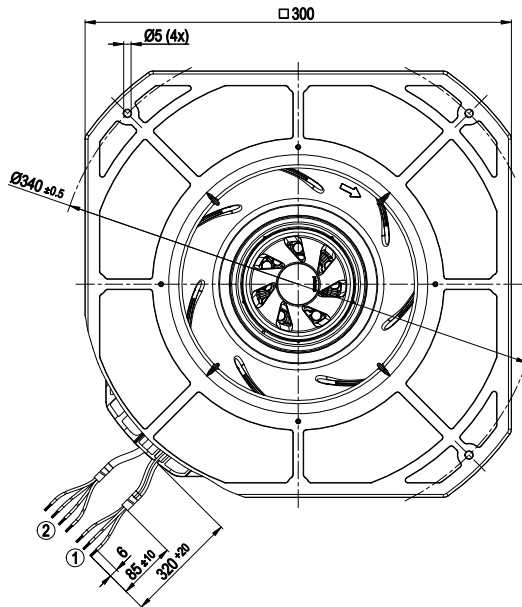

- ① Supply line (PWR) PVC AWG20, 3x splice
- ② Control wire (CTRL) PVC AWG22, 4x splice

Pin assignment: See connection diagram
Mounting position: Any

B VBH0250RSLFS 8300100185 EC centrifugal module - RadiCal

Dimensions in mm

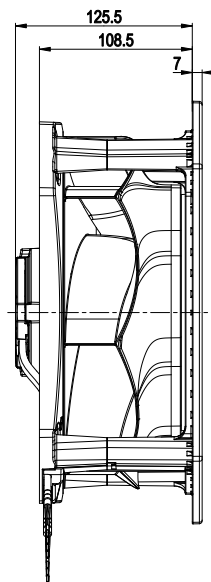
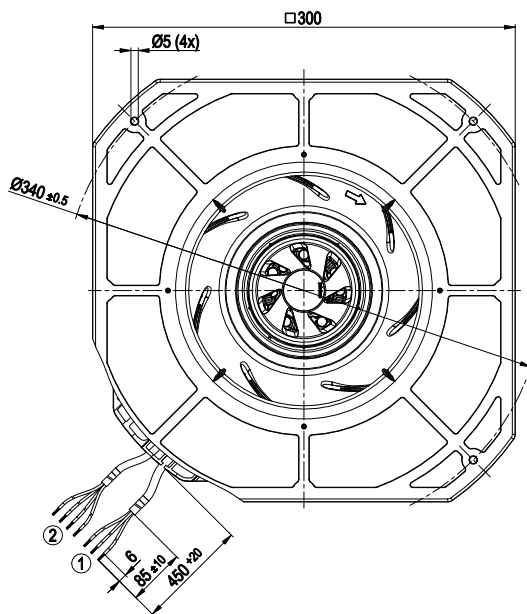

- ① Supply line (PWR) PVC AWG20, 3x splice
- ② Control wire (CTRL) PVC AWG22, 4x splice

Pin assignment: See connection diagram
Mounting position: Any

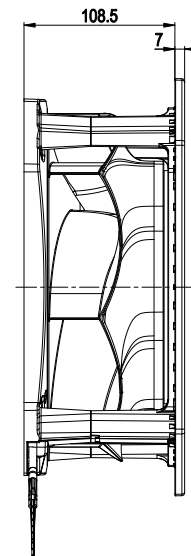
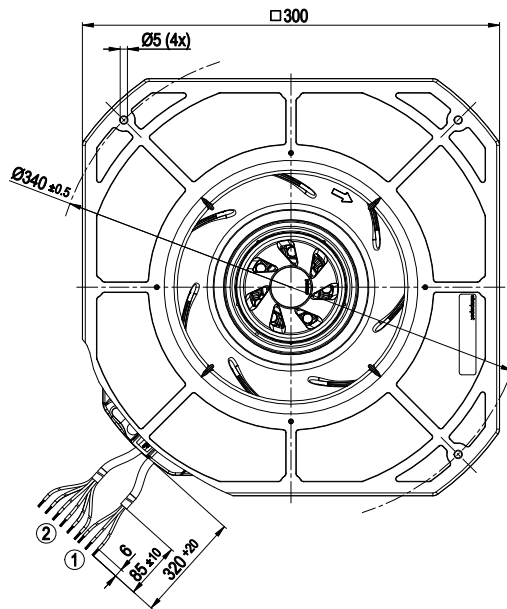

- ① Supply line (PWR) PVC AWG20, 3x splice
- ② Control wire (CTRL) PVC AWG22, 4x splice

Pin assignment: See connection diagram
Mounting position: Any

ebm-papst

EC centrifugal fans & modules

RadiCal Accesories

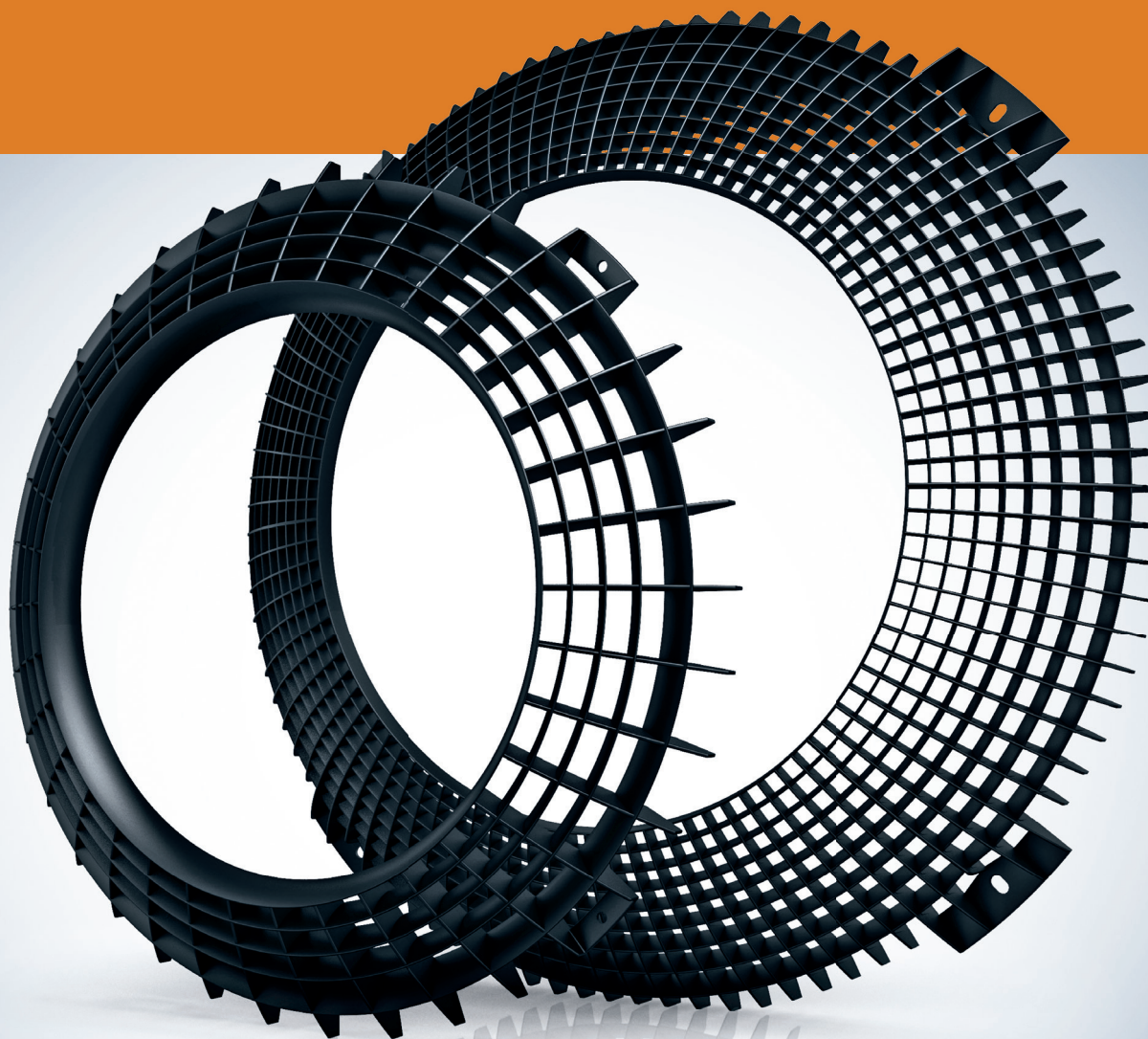

ebmpapst

engineering a better life

Accesories 190 - 250

	Page
FlowGrid air inlet grill	60
Intake guard grill	61
Inlet rings	62

FlowGrid air inlet grill

efficient noise reduction



ebm-papst fans are not measured on our own advanced test stands just for their air performance alone. The acoustic behavior of the fans is also examined and the measurement results are included in the technical documentation.

Please note that the measurements are taken under ideal conditions with undisturbed inflow and outflow. If the fans are subsequently installed and used in devices with rather tight spaces, it is to be expected that the noise data provided in the documentation will not be applicable.

In order to minimize the negative impact of the installation situation, ebm-papst offers the FlowGrid air-inlet guard shown here. It is installed on the intake side of the fan and effectively reduces the noise generated by the fan. Particularly annoying, low-frequency noises are reduced efficiently.

The level of noise reduction is dependent on the installation situation, which is why no generally applicable data is possible here.

FlowGrid air inlet grill

(for centrifugal module & spiral housing)

Part number	Fan size	Ø B (mm)	Ø C (mm)	Ø E (mm)	S (mm)	H (mm)	N* (Nm)
00190-2-2957 ^{1,)}	190	170	150-160	4,5	2,0	30	2±0,5
00200-2-2957 ^{2,)}	190	170	150-160	4,5	2,0	30	2±0,5
00250-2-2957 ^{1,)}	220, 225, 250	205	192-195	4,5	2,0	38	2±0,5

^{1,)} (FlowGrid is completely closed / protective grid function)

^{2,)} (FlowGrid is open)

Subject to changes.

* Recommended tightening torque for fastening screws

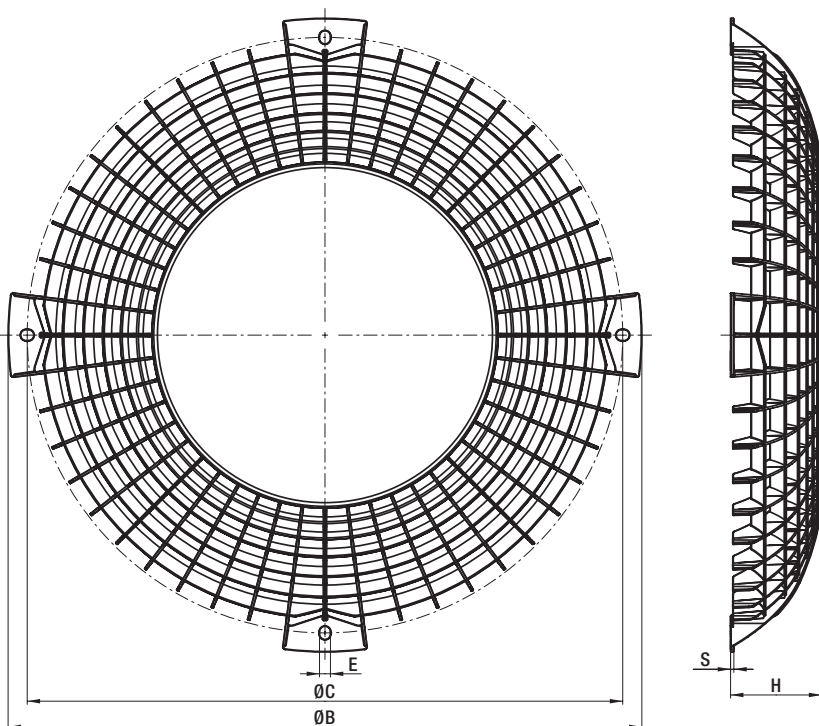

Would you like to find out more?

If you need an installation guide or more information about the dimensions, go to:

www.ebmpapst.com/flowgrid-manual

or scan the QR code below:



Intake guard grill

RadiCal

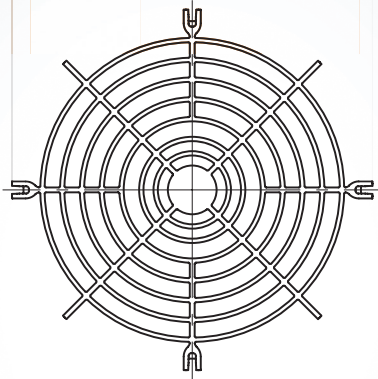

– **Material:** Plastic, fiberglass reinforced

– **Mounting:** The guard grille is easily mounted by means of 4 clamping devices clipped on.

Intake guard grill for Compact centrifugal modules

Part Number	Fan size	a (mm)	b (mm)
19051-2-2929	190	133	9,0
22051-2-2929	220	166	8,7
22551-2-2929	225	158	8,7
25051-2-2929	250	177	9,7

Subject to changes.

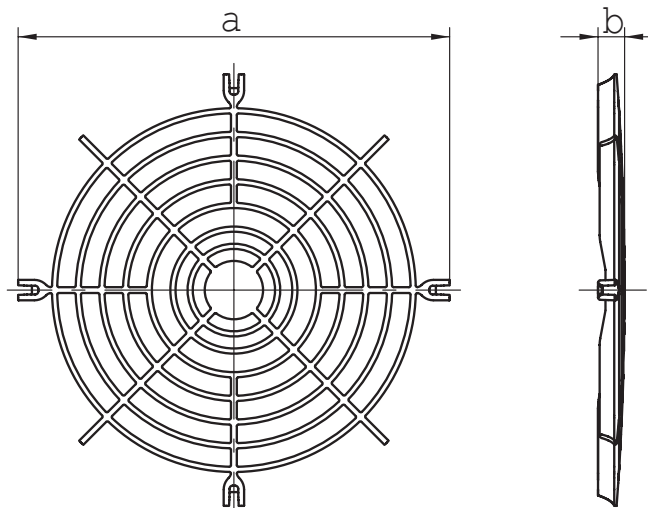

Inlet rings

with / without measuring device



– **Material:** Galvanized sheet steel

Inlet rings without measuring device for backwards-curved centrifugal fans RadiCal

Part number	Fan Size	Dimensions / drawing
09576-2-4013	190	see Page 63 (Pressure extraction by centrifugal modules see Page 63)
09609-2-4013	220	see Page 63 (Pressure extraction by centrifugal modules see Page 63)
96358-2-4013	225	see Page 63 (Pressure extraction by centrifugal modules see Page 63)
96359-2-4013	250	see Page 63 (Pressure extraction by centrifugal modules see Page 63)

Subject to changes.

Without measuring device:

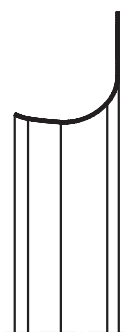

With one pressure tap:



With piezometer:

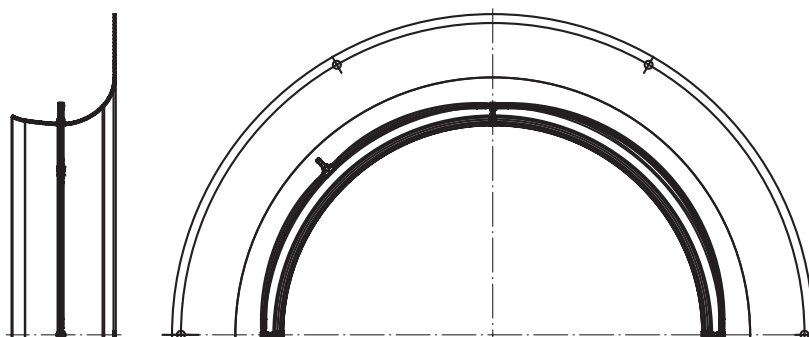

Inlet rings

Dimensioned drawings without measuring device

Fan size 190:

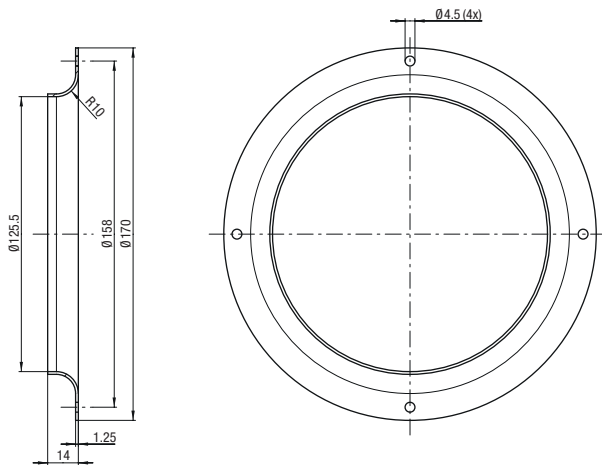

Fan size 220:

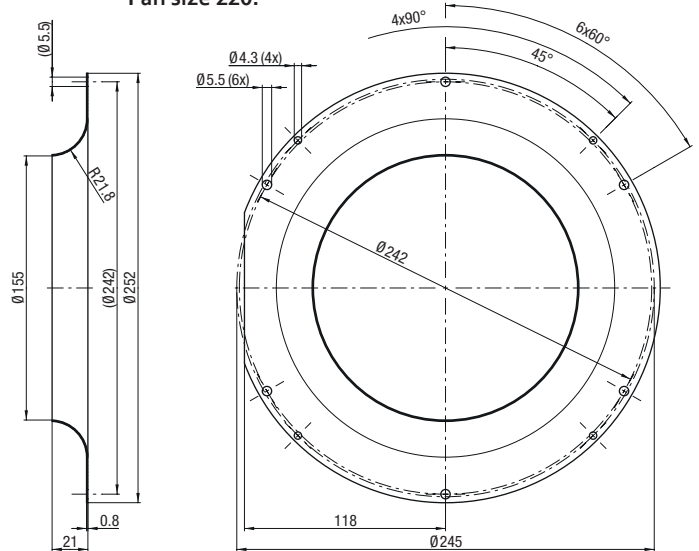

Fan size 225:

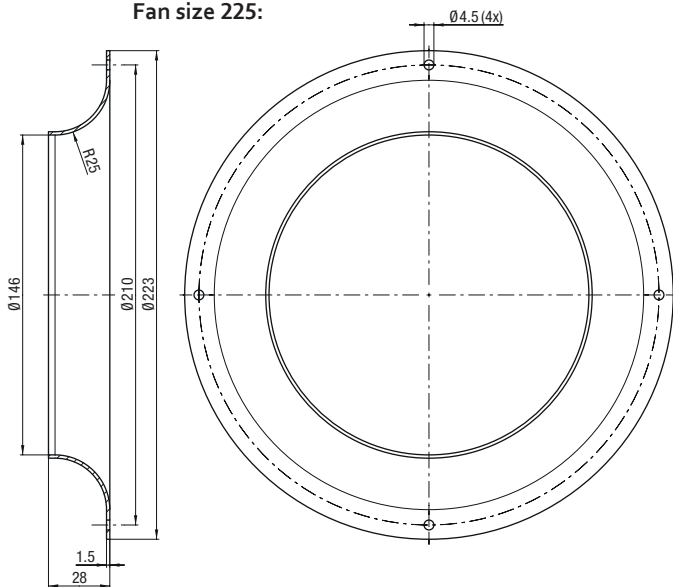

Fan size 250:

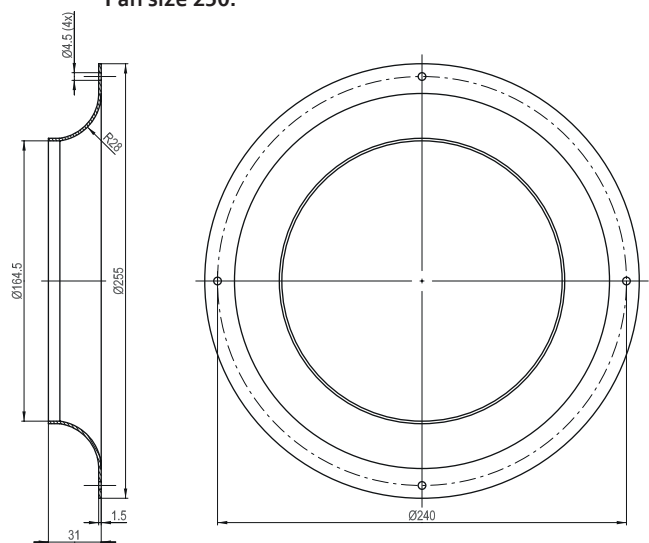

Pressure extraction for centrifugal modules, fan size 190 - 250

Part number	Component parts
20000-2-2945	Pressure transducer (A)
43426-4-5154	Closure cap for pressure transducer
79600-2-5120	T-tube connector (B)
02636-7-7024	Silicone tube (C)

Subject to changes.

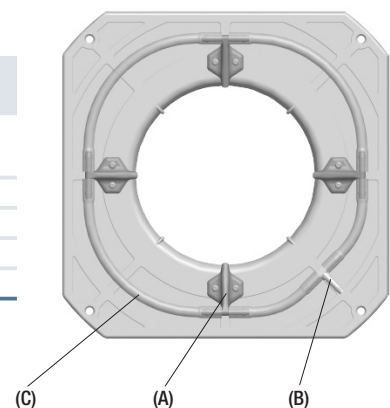

ebm-papst

EC centrifugal fans & modules RadiCal Technology



ebmpapst

engineering a better life

Technology 190 - 250

	Page
Connection diagrams	66
Air flow measurement	67
Technical parameters & scope	68

Connection diagrams

Technical features:

- Output 10 VDC max. 1,1 mA (85 W)
- Output 10 VDC max. 10 mA (120 & 170 W)
- Locked-rotor detection
- Tach output
- Speed control
- Power limiter
- Motor current limitation
- Soft start
- Control input 0-10 VDC / PWM
- Control interface with SELV potential safely disconnected from supply
- Thermal overload protection for electronics/motor
- Overvoltage detection
- Undervoltage detection

Supply line

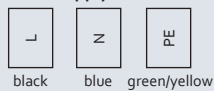

Control wire

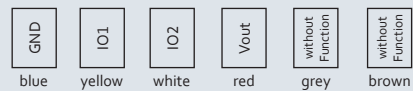

Air flow measurement

Air flow measurement:

The differential pressure method compares the static pressure upstream of the inlet ring with the static pressure in the inlet ring.

The air flow can be calculated from the differential pressure (between the static pressures) according to the following equation:

$$q_V = k \cdot \sqrt{\Delta p} \quad q_V \text{ in [m}^3/\text{h]} \text{ and } \Delta p \text{ in [Pa]}$$

If the air flow is to be regulated to remain constant, the inlet pressure must be kept constant:

$$\Delta p = q_V^2 : k^2 \quad q_V \text{ in [m}^3/\text{h]} \text{ and } \Delta p \text{ in [Pa]}$$

k takes into account the specific properties of the inlet ring.

The pressure is tapped at 1 (4) point(s) on the circumference of the inlet ring. The customer connection consists of a built-in T-shaped hose fitting. The hose fitting is suitable for pneumatic hoses with an inside diameter of 4 mm.

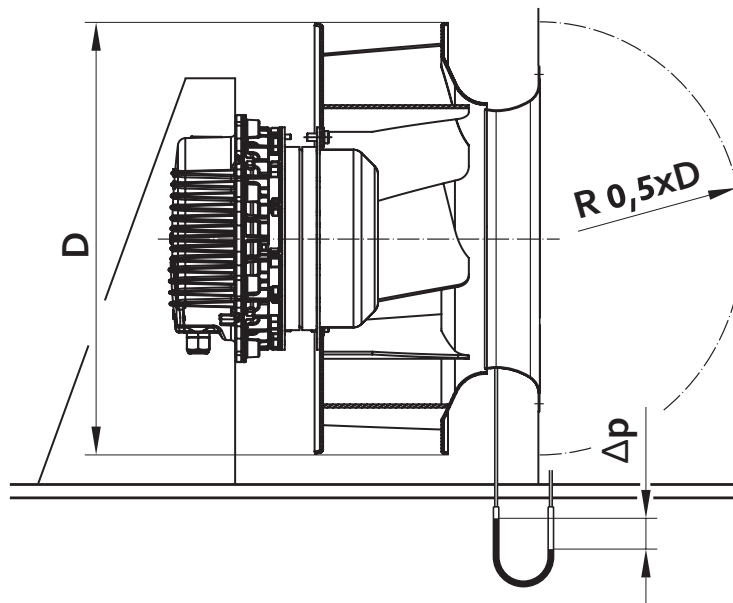

k-factors: (for RadiCal inlet rings)

Fan size	k-factor
190	30
220	50
225	48/51
250	60/61

Subject to changes.

Technical parameters & scope

High standards for all ebm-papst products

Here at ebm-papst, we constantly strive to further improve our products in order to be able to offer you the best possible product for your application. Careful monitoring of the market ensures that technical innovations are reflected in the improvements of our products. Based on the technical parameters listed below and the ambience you want our product to operate in, we here at ebm-papst can always work out the best solution for your specific application.

General performance parameters

Any deviations from the technical data and parameters described here are listed on the product-specific data sheet.

Degree of protection

The type of protection is specified in the product-specific data sheets.

Insulation class

The insulation class is specified in the product-specific data sheets.

Installation position

The mounting position is specified in the product-specific data sheets.

Condensate discharge holes

Information on the condensate discharge holes is provided in the product-specific data sheets.

Mode of operation

The mode of operation is specified in the product-specific data sheets.

Protection class

The protection class is specified in the product-specific data sheets.

Tightening torques for fan assembly

Please consult your ebm-papst contact for questions about which tightening torque to use.

Service life

The service life of ebm-papst products depends on two main factors:

- The service life of the insulation system
- The service life of the bearing system

The service life of the insulation system is essentially governed by the voltage level, the temperature and the ambient conditions such as humidity and condensation.

The service life of the bearing system is primarily governed by the thermal load on the bearings. For the majority of our products we use maintenance-free ball bearings which can be fitted in any installation position.

As a rough guide (depending on the general conditions), the ball bearings have a life expectancy L10 of approx. 40.000 hours of operation at an ambient temperature of 40 °C.

We will gladly provide you with a life expectancy calculation based on your specific usage conditions.

Motor protection/thermal protection

Information on motor protection and thermal protection is provided in the product-specific data sheets.

The following protection methods are provided depending on the type of motor and area of application:

- Thermal overload protector, in-circuit or external
- PTC with electronic diagnostics
- Impedance protection
- Thermal overload protector with electronic diagnostics
- Current limitation via electronics

If use is made of an external thermal overload protector, a commercially available tripping unit must be connected by the customer for shut-off. Motor protection conforming to the applicable standard must be fitted for products not provided with a built-in thermal overload protector and not protected against improper use.

Mechanical strain/performance parameters

All ebm-papst products are subjected to comprehensive testing in conformity with the normative specifications and also incorporating the extensive experience of ebm-papst.

Vibration testing

Vibration testing is performed as follows:

- Vibration test in operation according to DIN IEC 68 Part 2-6
- Vibration test at standstill according to DIN IEC 68 Part 2-6

Shock load

Shock load testing is performed as follows:

- Shock load according to DIN IEC 68 Part 2-27

Balancing grade

Balancing grade testing is performed as follows:

- Residual imbalance according to DIN ISO 1940
- Standard balancing quality level G 6.3

Should your particular application require a higher level of balancing, please contact us and specify the details in your order.

Chemical and physical strain/performance parameters

Please consult your ebm-papst contact for any questions regarding chemical and physical strain.

Areas of use, industries & applications

Our products are used in a variety of industries and for numerous applications:

Ventilation, air conditioning and refrigeration technology, clean room technology, automotive and railway engineering, medical and laboratory technology, electronics, computer and office systems, telecommunications, household appliances, heating systems, machinery and installations, drive engineering. Our products are not intended for use in the aerospace or military industries!

Legal and normative specifications

The products described in this catalog are developed and manufactured in accordance with the standards applying to the particular product and, if known, in accordance with the conditions of the particular area of application.

Standards

Information on standards is provided in the product-specific data sheets.

EMC

Information on EMC standards is provided in the product-specific data sheets. Compliance with EMC standards has to be assessed on the final product, as EMC properties may change under different installation conditions.

Touch current

Information on touch current is provided in the product-specific data sheets. Measurement is performed according to IEC 60990.

Approvals

Please contact us if you require a specific type of approval (VDE, UL, GOST, CCC, CSA, etc.) for your ebm-papst product. Most of our products can be supplied with the applicable approval. Information on existing approvals is provided in the product-specific data sheets.

Air performance measurements

All air performance measurements are conducted on intake-side chamber test rigs conforming to the requirements of ISO 5801 and DIN 24163. The fans under test are attached to the measuring chamber with free air intake and exhaust (installation category A) and operated at nominal voltage, with alternating current also at nominal frequency, without any additional attachments such as a guard grill.

As required by the standards, the air performance curves shown are referenced to an air density of 1,15 kg/m³.

Technical parameters & scope

Acoustic

Air and sound measurement conditions

Measurements on ebm-papst products are taken under the following conditions:

- Axial and diagonal fans in airflow direction "V" in full nozzle without guard grill
- Backward-curved centrifugal fans, free-running with inlet ring
- Forward-curved single and dual-inlet centrifugal fans with housing
- Backward-curved dual-inlet centrifugal fans with housing

Sound measurements

All sound measurements are taken in anechoic rooms with reverberant floor. ebm-papst acoustic test chambers meet the requirements of accuracy class 1 as per DIN EN ISO 3745.

For sound measurement, the fans being tested are positioned in a reverberant wall and operated at nominal voltage, with alternating current also at nominal frequency, without any additional attachments such as a guard grill.

Sound pressure and sound power level

All acoustic values are determined in accordance with ISO 13347, DIN 45635 and ISO 3744/3745 as per accuracy class 2 and given in A-rated form.

For measurement of the sound pressure level L_p the microphone is located on the intake side of the fan being tested, generally at a distance of 1 m on the fan axis.

For measurement of the sound power level L_w 10 microphones are distributed over an enveloping surface on the intake side of the fan being tested (see graphic). The measured sound power level can be roughly calculated from the sound pressure level by adding 7 dB.

Measurement set-up according to ISO 13347-3 and DIN 45635-38:

- 10 measuring points

$$d \geq D$$

$$h = 1,5d \dots 4,5d$$

$$\text{Measurement area } S = 6d^2 + 7d(h + 1,5d)$$

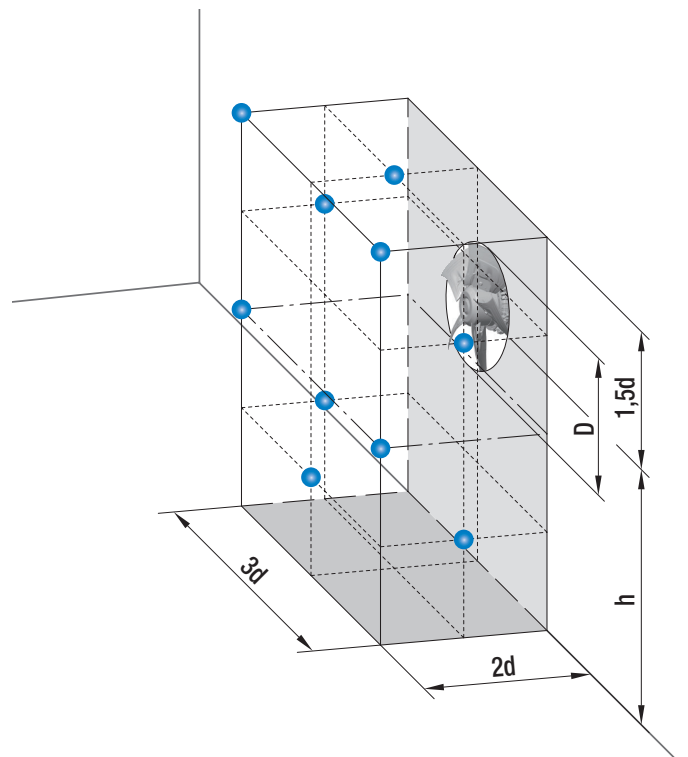

Cumulative level of several sound sources with the same level

The addition of 2 sound sources with the same level produces a level increase of approx. 3 dB.

The noise characteristics of several identical fans can be predicted on the basis of the sound values specified in the data sheet. This is shown in the adjacent graph.

Example: There are 8 axial fans A3G800 on a condenser. According to the data sheet, the sound pressure level of one fan is 75 dB(A). The level increase determined from the graph is 9 dB. This means that a total level of 84 dB(A) is to be expected for the installation.

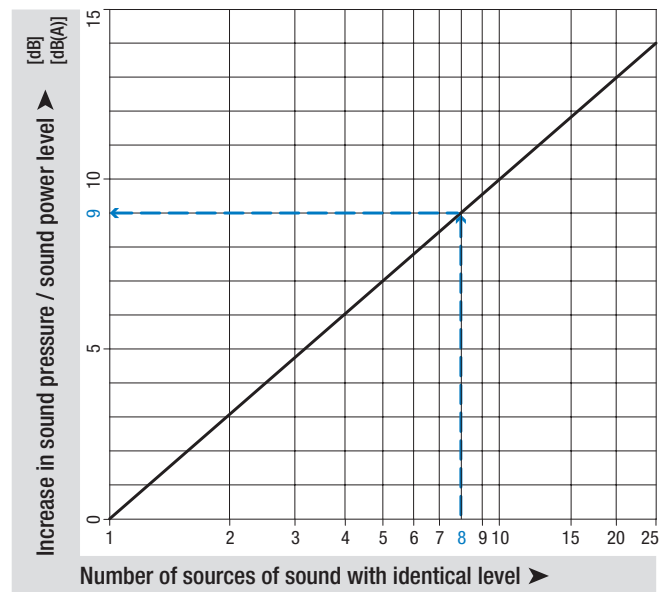

Cumulative level of two sound sources with different levels

The noise characteristics of two different fans can be predicted on the basis of the sound values specified in the data sheet. This is shown in the adjacent graph.

Example: In a ventilation unit, there is one axial fan A3G800 with a sound pressure level of 75 dB(A) at the point of operation and one axial fan A3G710 with 71 dB(A). The difference in level is 4 dB. The level increase of approx. 1.5 dB can now be read off the graph. This means that a total level of 76.5 dB(A) is to be expected for the unit.

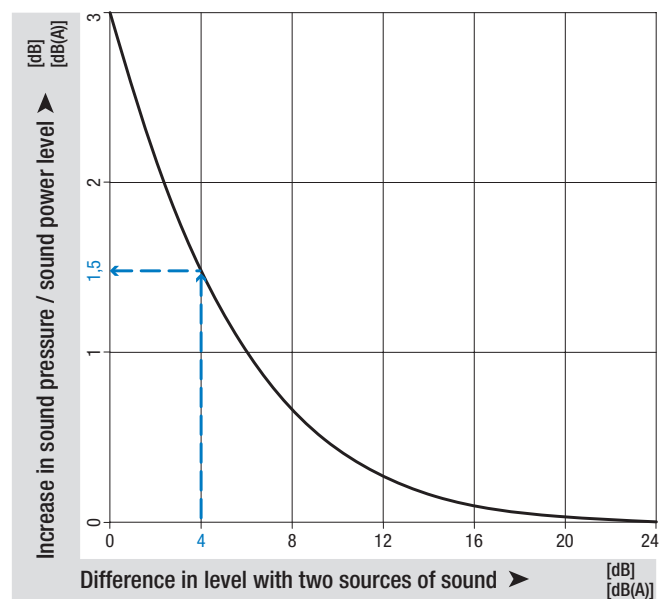

Distance laws

The sound power level is not governed by the distance from the noise source. By contrast, the sound pressure level decreases with increasing distance from the sound source. The adjacent graph shows the decrease in level under far field conditions. Far field conditions apply if there is a considerable distance between the microphone and the fan in relation to the fan diameter and the wavelength under consideration. On account of the complexity of the topic, literature should be consulted for more detailed information on far fields. The level in the far field decreases by 6 dB each time the distance is doubled. Different relationships apply in the near field of the fan and the level may decrease to a far lesser extent. The following example only applies to far field conditions and may vary considerably as a result of installation effects:

For an axial fan A3G300, a sound pressure level of 65 dB(A) was measured at a distance of 1 m. From the adjacent graph, this would yield a reduction of 26 dB at a distance of 20 m, i.e. a sound pressure level of 39 dB(A).

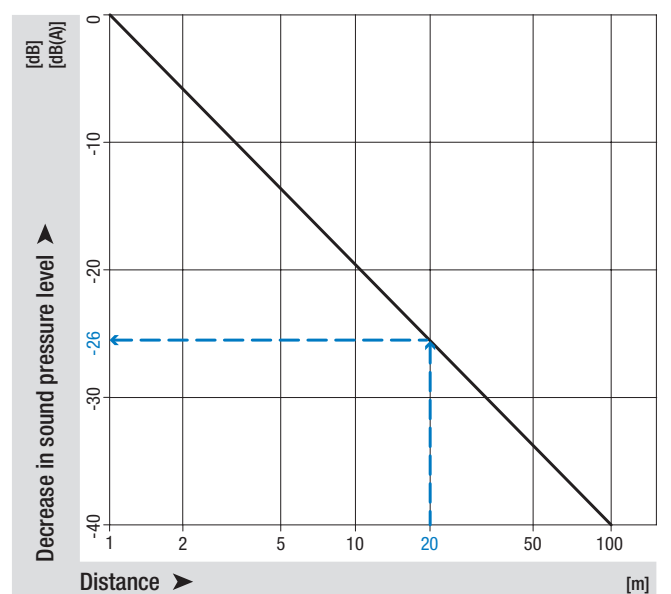

EC centrifugal fans RadiCal

Contacts – Worldwide



ebmpapst
engineering a better life

Always find the right contact person!

ebmpapst.com/contact



Germany

ebm-papst Mulfingen GmbH & Co. KG

Bachmühle 2
74673 Mulfingen
GERMANY
Phone +49 7938 81-0
Fax +49 7938 81-110
info1@de.ebmpapst.com

ebm-papst St. Georgen GmbH & Co. KG

Hermann-Papst-Straße 1
78112 St. Georgen
GERMANY
Phone +49 7724 81-0
Fax +49 7724 81-1309
info2@de.ebmpapst.com

ebm-papst Landshut GmbH

Hofmark-Aich-Straße 25
84030 Landshut
GERMANY
Phone +49 871 707-0
Fax +49 871 707-465
info3@de.ebmpapst.com

Notes

Notes

ebmpapst

engineering a better life

ebm-papst
Mulfingen GmbH & Co. KG

Bachmühle 2
74673 Mulfingen
Germany
Phone +49 7938 81-0
Fax +49 7938 81-110
info1@de.ebmpapst.com